



MISTRAL MDX

Air-to-air VRF heat pump system
for large spaces

Sustainable heating and cooling with the Mark MDX
VRF system. Powers of 33 and 56 kW.



For more information, downloads and
videos, visit the MISTRAL MDX page on
our website

Sustainable heating and cooling with the Mark MISTRAL MDX



The Mark MISTRAL MDX is a VRF system, which is specially developed for energy-efficient heating and cooling of large spaces. The combination of an air-to-air heat pump (outdoor unit) with a compact air heater / cooler (indoor unit) ensures excellent performance. Thanks to the extensive setting options, the installation can be fully adapted to the use of the building and the wishes of the users.

Thanks to the long available pipe lengths (90m MDX 33/ 170m MDX 56) and the wide temperature range, the MISTRAL MDX has many application options. Suitable for heating and cooling garages, warehouses, workshops, distribution centers and showrooms.

Product features

- Available with powers of 33 kW and 56 kW
- Air to air heat pump VRF-system
- Cooling and heating
- Large temperature range
- Indoor unit with EC fan
- Energy efficient
- Pipe length: (90m MDX 33/ 170m MDX 56)
- Refrigerant: R410a
- Optional: integrated condensate pump

Ambient temperature range (indoor unit):

- Cooling: +17°C - +43°C
- Heating: +7°C - +25°C



Dimensions - indoor unit

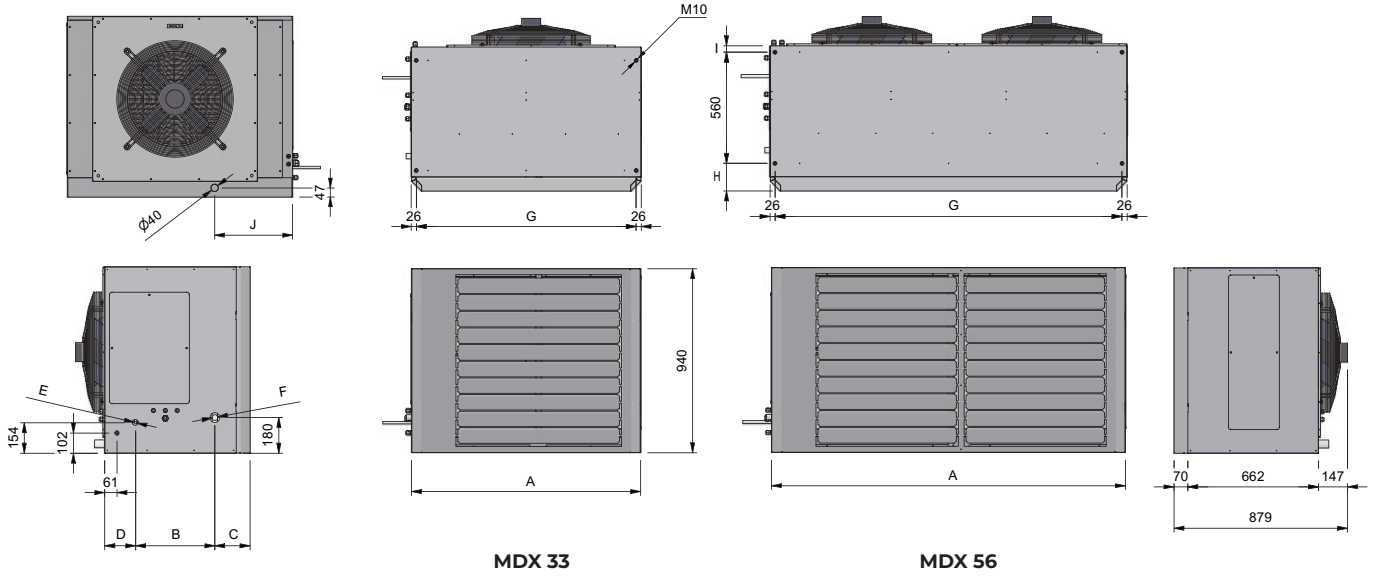

TYPE	A	B	C	D	E	F	G	H	I	J	K
MDX 33	1170	399	178	156	28	1/2"	1118	105	68	404	47
MDX 56	1800	373	206	154	28	5/8"	1748	140	33	389	47

Dimensions - outdoor unit

MDX 33

MDX 56

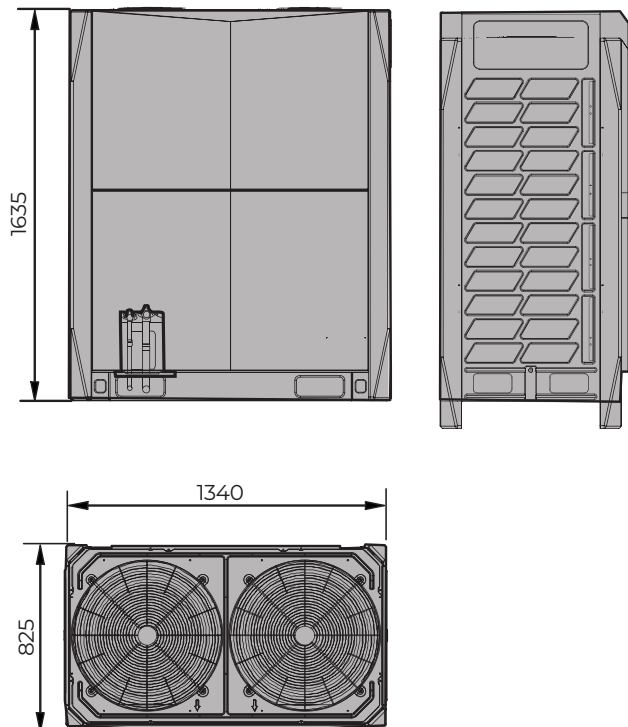
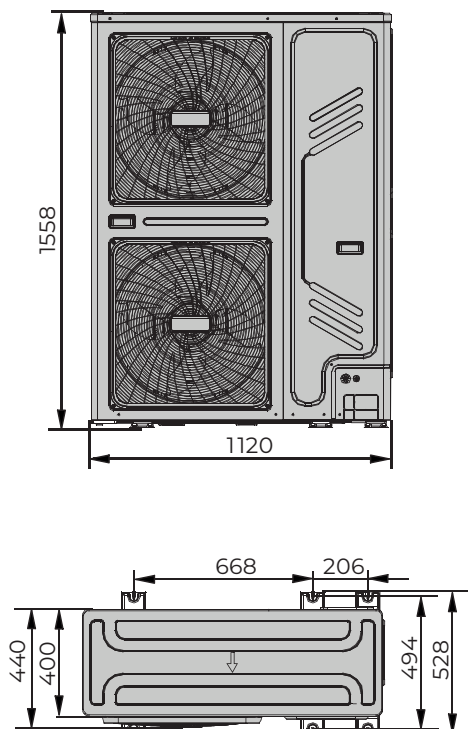

Technical information

Type			MDX 33	MDX 56
Power		HP	12	20
heating	Nominal capacity ²	kW	37,5	63,0
	Absorbed power ²	kW	9,08	19,21
	Nominal capacity ³	kW	30,7	51,6
	Absorbed power ³	kW	10,79	22,83
SCOP			3,96	4,31
cooling	Nominal capacity ¹	kW	33,5	56
	Absorbed power ¹	kW	15,3	16
	EER ¹		2,19	3,5
Electrical data				
Power supply		Ph/V/Hz	3/380-415/50	3/380-415/50
Nominal Consumed current		A	19,6	35
Maximum current		A	26,4	45,9
Fuse		A	32	50
Refrigerant features				
Refrigerant			R410A	R410A
Refrigerant content ⁴		kg	8	17 ⁵
DC Inverter compressor		no. / type	1 / Rotary DC Inverter	2 / Scroll DC Inverter
Pipe connections	Liquid	Ø inch	1/2"	5/8"
	Gas	Ø mm	28	28
Distance indoor and outdoor unit	min	m	2	2
	max	m	90	170
Maximum height difference		m	40	90
Specifications outdoor unit				
Dimensions (LxHxD)		mm	1120x1558x528	1340x1635x825
Net weight		kg	157	344
Sound pressure level (5 mtr.)		max dB(A)	47	52
Air flow		max m ³ /h	11300	17000
Operating limits (outside temperature)	Cooling	°C	-5 ~ +48	-5 ~ +48
	Heating	°C	-20 ~ +24	-23 ~ +24
Specifications indoor unit				
Weight		kg	112	160
Air flow		max m ³ /h	6600	11200
Sound pressure level (5 mtr.) at max air flow		dB(A)	53	56
Throw		m	19	22
Pipe connections	Liquid	Ø mm (inch)	12,7 (1/2")	15,8 (5/8")
	Gas	Ø mm	28	28
Power supply		Ph/V/(Hz)kW	1/230/(50)0,24	1/230/(50)0,48
Temperature range	Cooling	°C		+17 ~ +43
	Heating	°C		+7 ~ +25

¹ Indoor air temperature 27°C DB, 19°C WB; outdoor air temperature 35°C DB; equivalent refrigerant piping length 7.5m with zero level difference.

² Indoor air temperature 20°C DB, 19°C WB; outdoor air temperature 7°C DB, 6°C WB; equivalent refrigerant piping length 7.5m with zero level difference.

³ Indoor air temperature 16°C DB, 19°C WB; outdoor air temperature -19,8°C DB, -20°C WB; equivalent refrigerant piping length 7.5m with zero level difference.

⁴ Excl. liquid line refill

⁵ Refill 5.2 kg on location, excluding refill liquid line.

Assembly/location suggestions

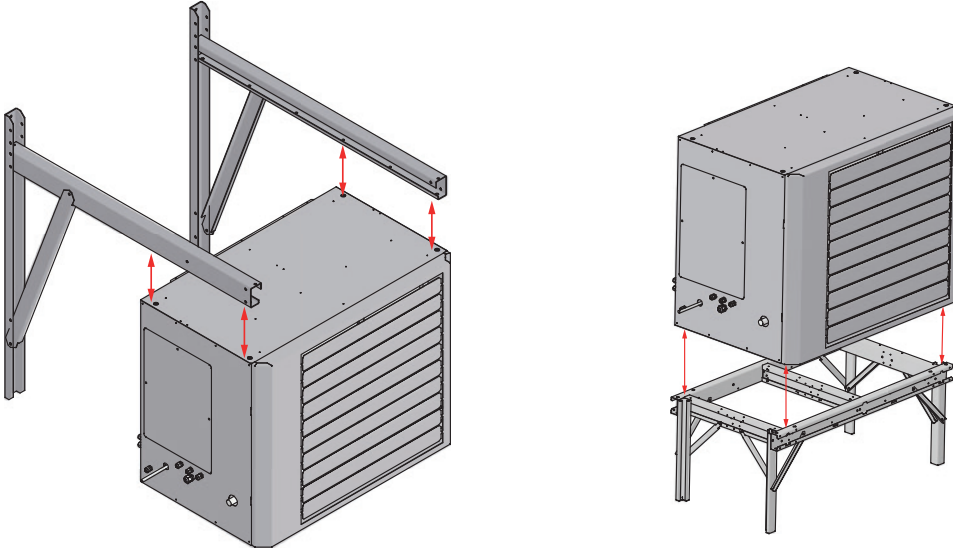

Controls



Control combination options

Mistral MDX + **1** + **2**

See price list for description and code numbers of the relevant items

