

mark[®]

building climate technology

Technical manual **EN**

MARK MISTRAL MDX 33/56

0662080V8_R06

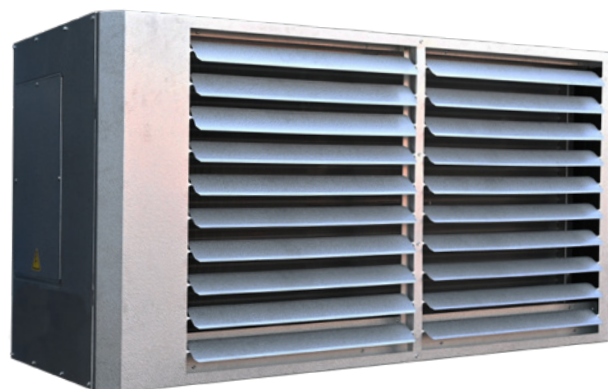

READ THIS DOCUMENT BEFORE INSTALLING THE HEATER

Warning

Incorrect installation, adjustment, alteration, repair or maintenance work may lead to material damage or injury. All work must be carried out by certified, qualified professionals. If the appliance is not positioned in accordance with the instructions, the warranty shall be rendered void. This appliance is not intended for use by children or persons with a physical, sensory or mental handicap, or who lack the required experience or expertise, unless they are supervised or have been instructed in the use of the appliance by somebody who is responsible for their safety. Children must be supervised to ensure that they do not play with the appliance.

EN

1 General

1.1 Application

Appliance type MISTRAL MDX is solely suitable for the free and direct intake of the air to be heated and the free discharge of heated air into the room. If areas are to be heated in which corrosive vapours are present (chlorinated hydrocarbons in particular), which are either produced directly in the area, or which may be drawn in from the outside by the heater via a duct or an open connection, wall air heaters cannot be used because of the risk of corrosion to the heat exchanger.

Subject to change

The manufacturer is committed to constantly improving its products and reserves the right to make changes in the specifications without prior notice. The technical details are considered correct but do not form the basis for a contract or warranty. All orders are accepted according to the standard terms of our general sales and delivery conditions (available upon request). The information in this document is subject to change without notice. The most recent version of this manual is always available at www.markclimate.com/downloads.

1.2 General warnings

Incorrect installation, adjustment, alteration, maintenance or repair of the MISTRAL MDX may lead to material or environmental damage and/or injuries. The appliance should therefore be installed, adapted or converted by a qualified and certified installer, taking into account national and international regulations. Faulty installation, adjustment, alteration, maintenance activity or repair shall render the warranty void.

2 Technical specifications

2.1 Technical specifications

Type			MDX 33	MDX 56
Specifications indoor unit				
Weight		kg	112	160
Air flow	max	m ³ /h	6600	11200
Sound pressure level (5 mtr.) at max air flow		dB(A)	53	56
Throw		m	19	22
Pipe diameter	Liquid	Ø mm (inch)	12,7 (1/2")	15,8 (5/8")
	Gas	Ø mm	28	28
Design pressure R410A	Hi	Mpa	4,2	4,2
	Lo	Mpa	3,4	3,4
Power supply		Ph/V/(Hz)kW	1/230/(50)0,24	1/230/(50)0,48
Temperature range	Cooling	°C	+17 ~ +43	+17 ~ +43
	Heating	°C	+7 ~ +25	+7 ~ +25
Condensate ¹		kg/h	12	19

¹ Indoor air temperature 27°C and 50% humidity

2.2 Dimensions

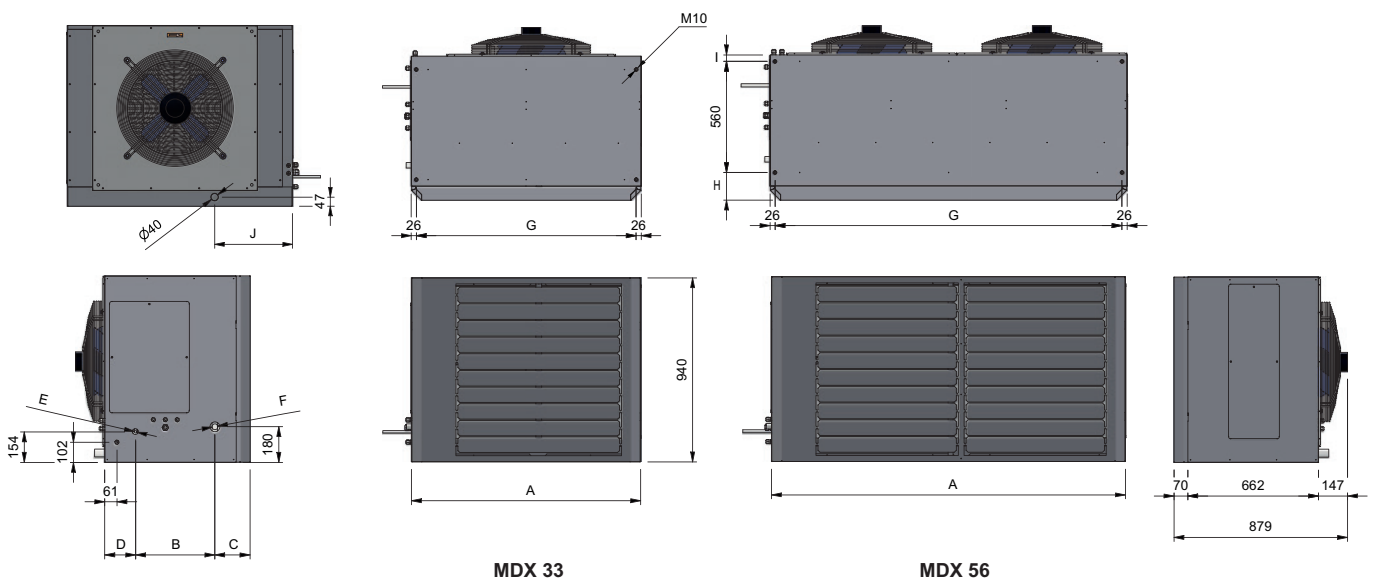

Type	A	B	C	D	E	F	G	H	I	J	K
MDX 33	1170	399	178	156	1/2"	28	1118	105	68	404	47
MDX 56	1800	373	206	154	5/8"	28	1748	140	33	389	47

2.3 Assembly suggestions

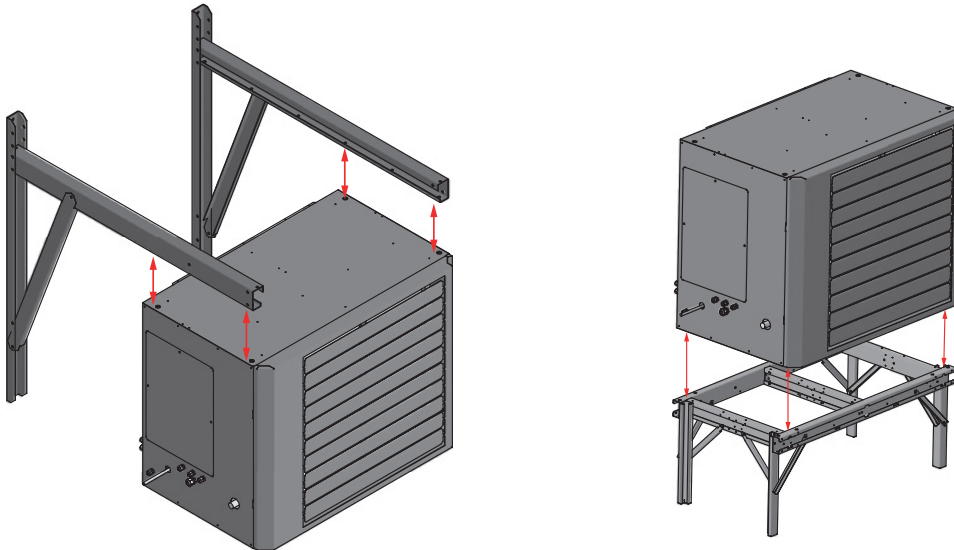

EN

3 Unit Placement and Installation

3.1 Positioning the appliance

After unpacking, check the appliance for damage. Check that the information relating to the type/model and the electrical voltage is correct. Place the appliance and any accessories to a sufficiently solid structure, taking into account the minimum free space required.

3.2 Indoor units

3.2.1 Placement considerations

Placement of indoor units should take account of the following considerations:

- » Indoor units should not be exposed to direct radiation from a high-temperature heat source.
- » Indoor units should not be installed in positions where dust or dirt may affect heat exchangers.
- » Indoor units should not be installed in locations where exposure to oil or to corrosive or harmful gases, such as acidic or alkaline gases, may occur.
- » Indoor units should be installed in well-drained, well-ventilated positions that are as close as possible to the outdoor units.
- » If applicable, sufficient space for drain piping and for access during servicing and maintenance should be allowed.
- » To ensure a good cooling/heating effect, short-circuit ventilation (where outlet air returns quickly to a unit's air inlet) should be avoided.
- » To prevent excessive noise or vibration during operation, suspension rods or other weight-bearing fixings should typically be able to bear twice the unit's weight.
- » Before installing an indoor unit, check that the model to be installed is as specified in the construction drawings and confirm the correct orientation of the unit.
- » Ensure that units are installed at the correct height.
- » To allow smooth condensate drainage and to ensure unit stability (to prevent excessive noise or vibration), ensure that units are level to within 1° of the horizontal. If a unit is not level to within 1° of the horizontal, water leakage or abnormal vibration/noise may occur.

3.2.2 Spacing

For indoor units to function properly, a sufficient air flow through the heat exchanger must take place. The spacing of the indoor units must take into account that sufficient air may flow through each unit. Figures 3.1 to 3.3 show spacing requirements in three different scenarios.

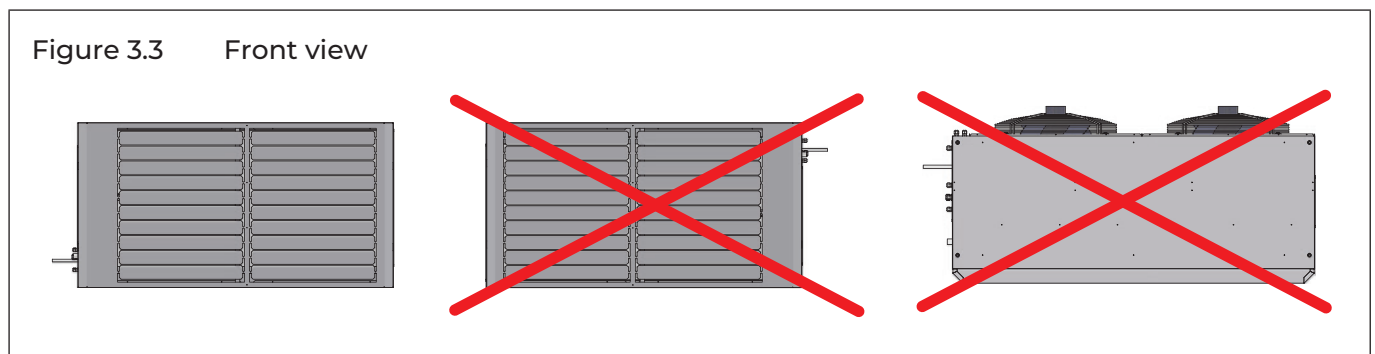
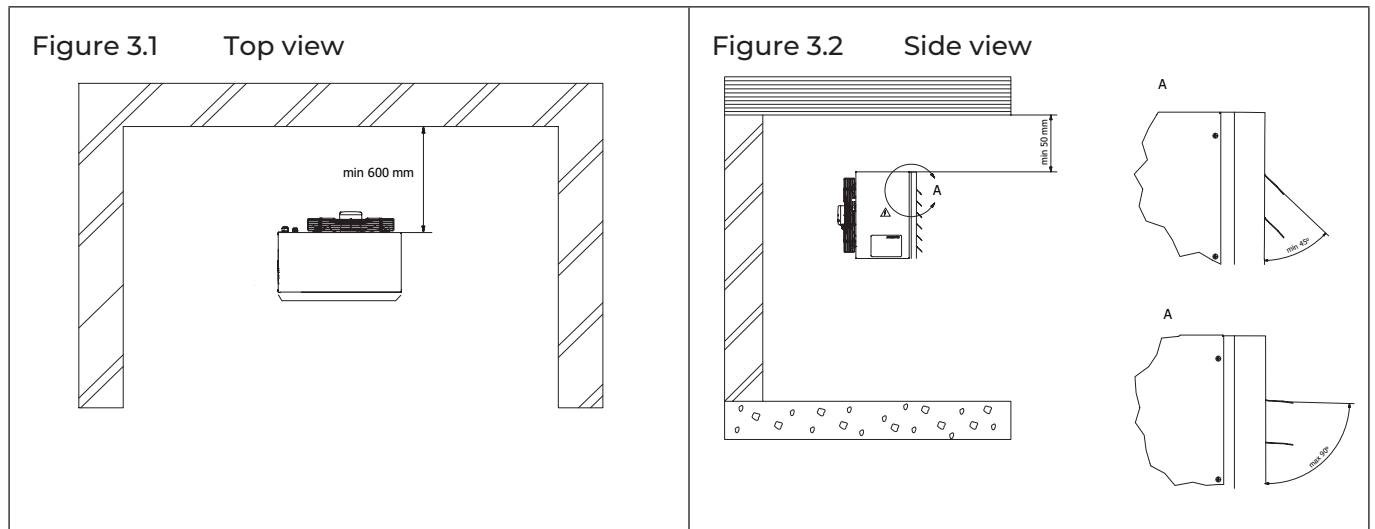

3.2.4 Acceptance and unpacking

- » When units are delivered, check whether any damage occurred during shipment. If there is damage to the surface or outside of a unit, submit a written report to the shipping company.
- » Check that the model, specifications and quantity of the units delivered are as ordered.
- » Check that all accessories ordered have been included. Retain the technical manual for future reference.

3.2.5 Hoisting

- » Do not remove any packaging before hoisting. If units are not packaged or if the packaging is damaged, use suitable boards or packing material to protect the units.
- » Hoist one unit at a time, using two ropes to ensure stability.

3.3 Condensate drain (optional)

If the Mistral MDX is used for heating only, a condensate drain is not necessary.

Type			MDX 33	MDX 56
Condensate ¹		kg/h	12	19

¹ Indoor air temperature 27°C and 50% humidity

3.3.1 Condensate drain with natural progression

The condensate drain must meet the criteria as described in the manual of the outdoor unit.

EN

Figure 3.3 Condensate drain without pump

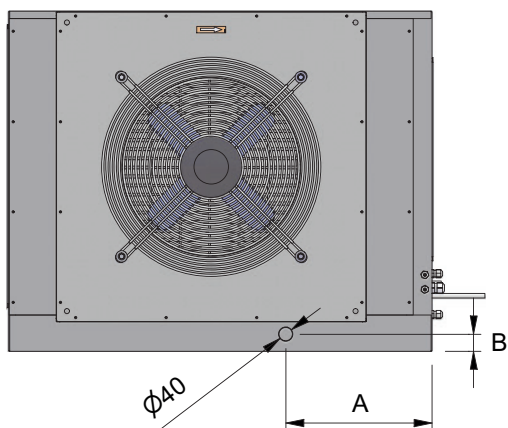

Type	A	B
MDX 33	404	47
MDX 56	389	47

3.3.2 Condensate drain with condensate pump

If there is a condensate drain pump in the Mistral MDX, then the pipe to drain the condensed water must be connected to the Mistral MDX. The drain must meet the criteria as described in the manual of the outdoor unit.

Figure 3.4 Condensate drain with pump

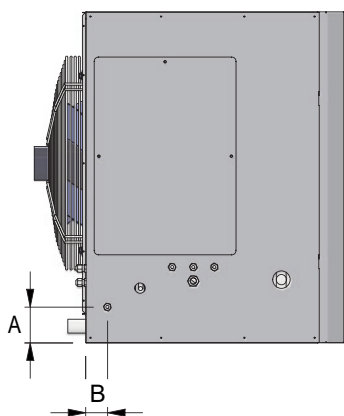

Type	A	B
MDX 33	102	61
MDX 56	102	61

Figure 3.5

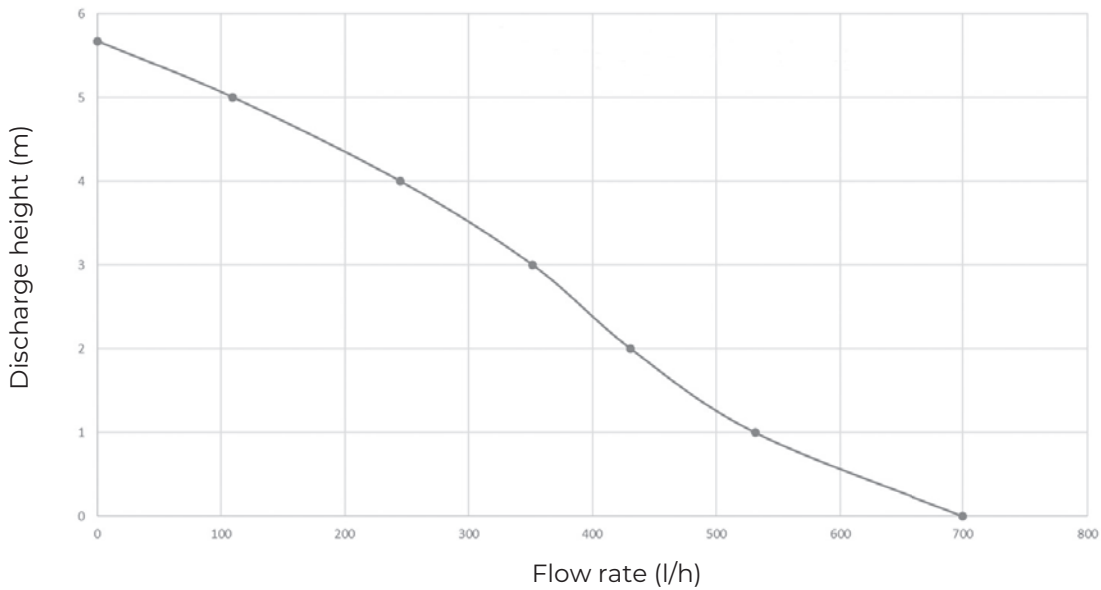

3.4 Outdoor units

For placement of the outdoor unit, please see the technical manual of the specific outdoor unit.

4 Maintenance

4.1 Cleaning

For optimal performance, the Mistral MDX has to be cleaned on a regular basis.

4.2 Cleaning air diverter plate

An air diverter plate is present in the Mistral MDX. This serves to divert the blown air over the battery. As a result, no high speed differences arise.

The air diverter plate becomes dirty over time, which affects the functioning. The plate should be cleaned annually or more often if necessary. The Mistral MDX 33 has one diverter plate, the Mistral MDX 56 has two diverter plates. These two diverter plates are connected to each other shown in Figure 4.1. Take this into account while removing and placing back the diverter plates.

Figure 4.1 Cleaning air diverter plate

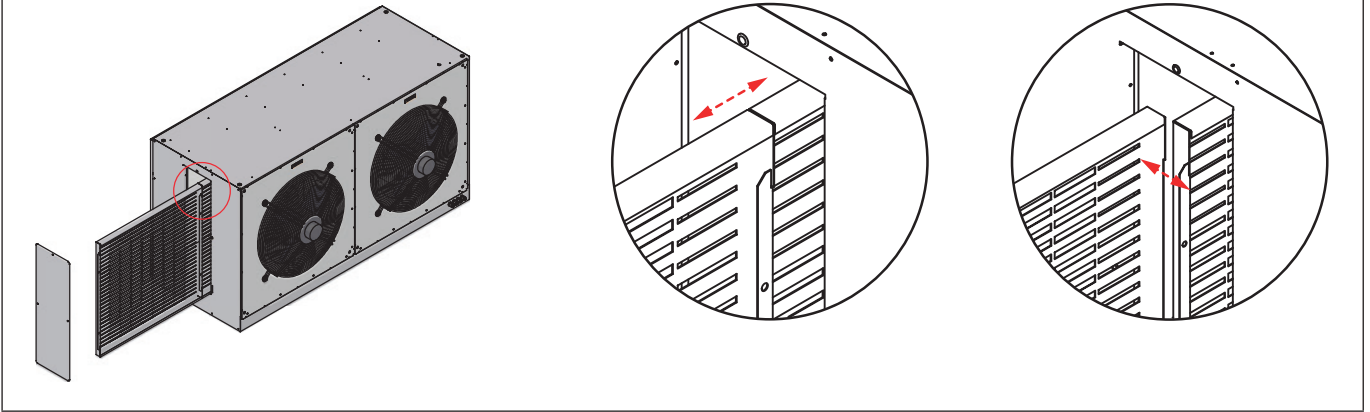

EN

4.3 Replacing a broken condensate pump

When the condensate drain pump breaks down, it must be replaced. The location of the pump is shown in the figure.

Figure 4.4 Replacing a broken condensate pump

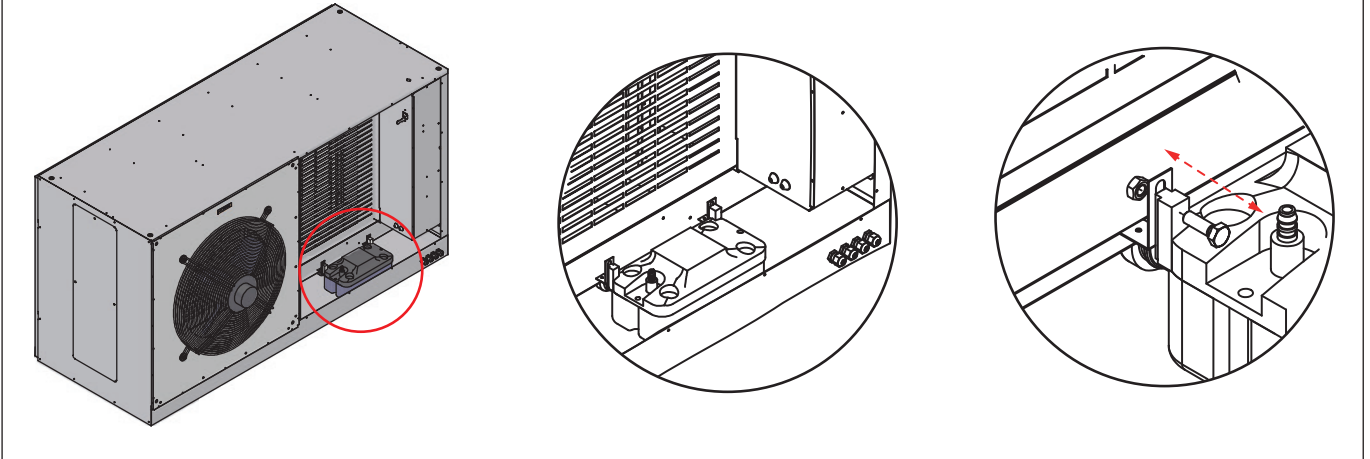

4.3 Positioning sensors

- T1 = Incoming air temperature
- T2A = Average battery temperature
- T2 = Incoming refrigerant temperature
- T2B = Outgoing air temperature
- TA = Outgoing refrigerant temperature

There are five sensors in the Mistral MDX. These are mounted in the places as shown in the Figures 4.5-4.8. If one or more sensors fail, they must be replaced. Sensor T1 can be replaced via the control box. To replace the other four sensors, it is first necessary to disassemble the outlet louvre.

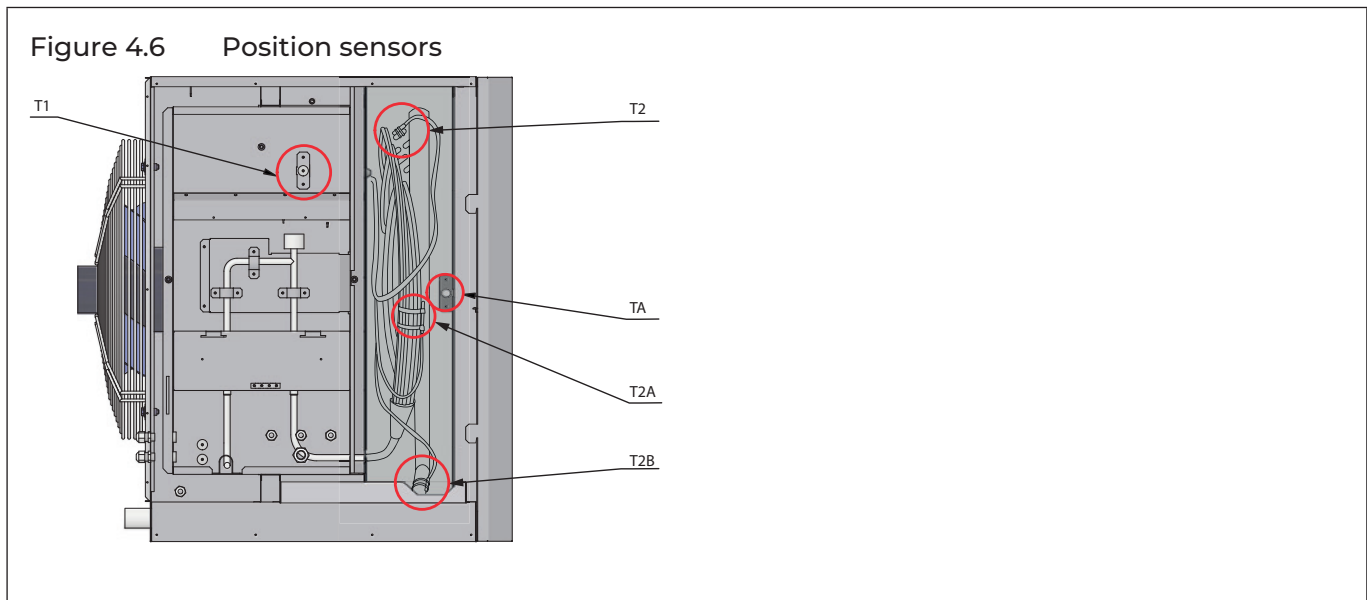
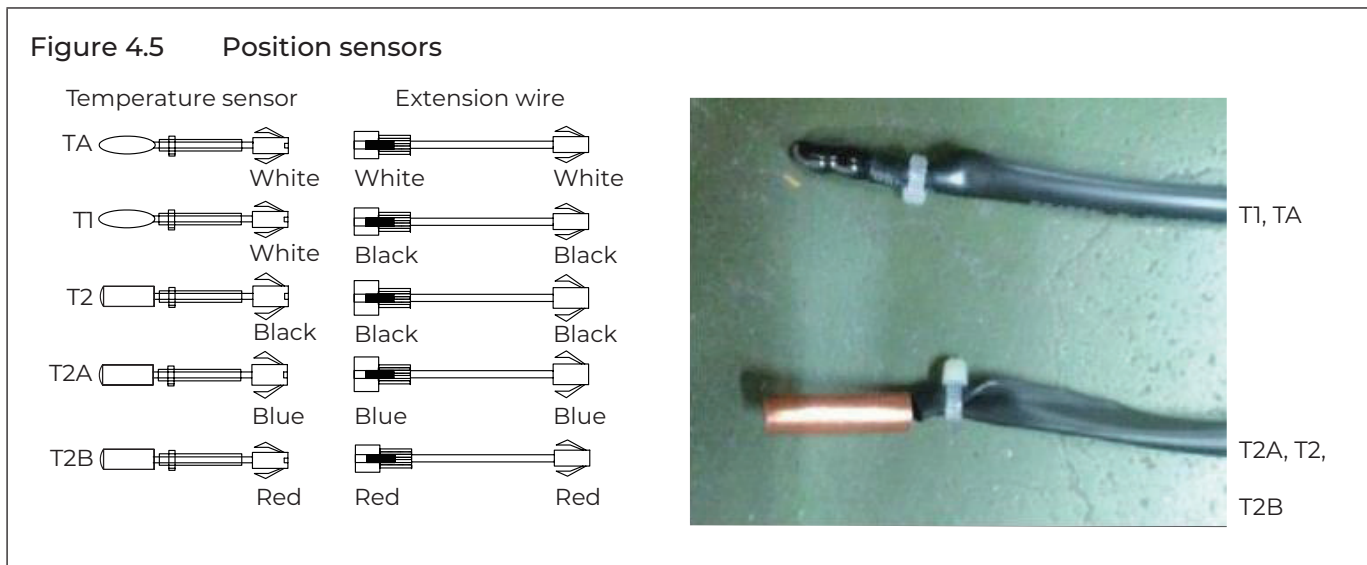
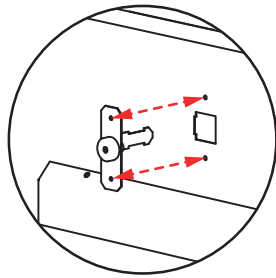
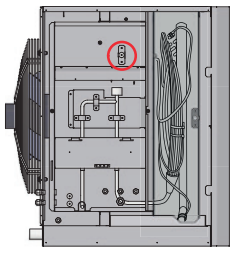
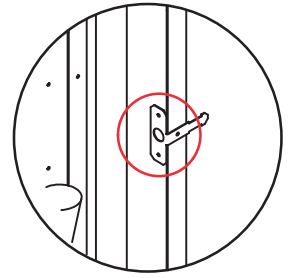
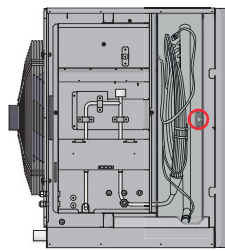

Figure 4.7 Position sensors

T1



TA



T2

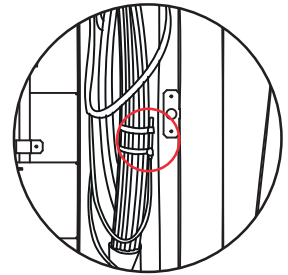
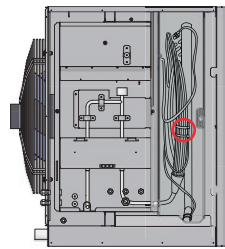
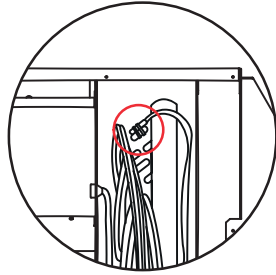
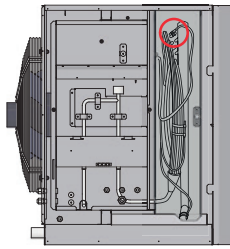

T2B

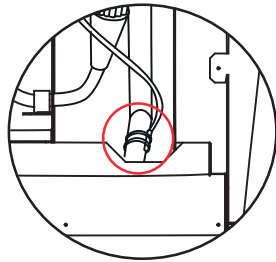
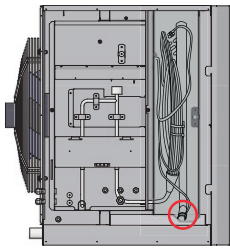

EN

When mounting the sensors, it is important that moisture cannot enter the sensors.

Figure 4.8 Position sensors

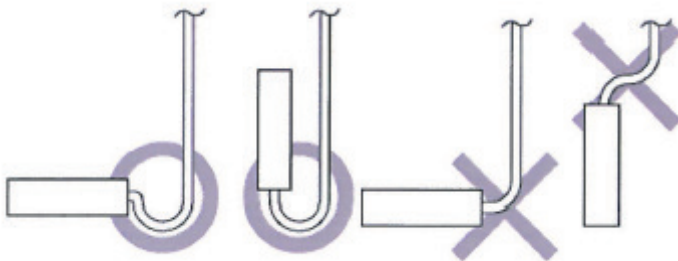

5 Refrigerant Piping

For information about the refrigerant piping, please see the technical manual of the specific Mistral MDX outdoor unit.

6 Control board settings



6.1 0-10V Output control

The DIP switch numbers of ENC2, ENC3 and ENC4 correspond to different voltage outputs. Depending on the DIP switch numbers of SW1-2, there are two control modes available, which are gear 1 and gear 3 fan speeds, respectively.

1. SW1-2 dialled to “OFF” (factory default)

ENC2, ENC3 and ENC4 are respectively defined as low, middle and high voltage output signals. By default, ENC2 is set to 2V, ENC3 is set to 7V, and ENC4 is set to A (A is 10V). See the table below for their corresponding relations:

Figure 6.1 0-10V output Voltage



ENC2  (2V Factory Default)					ENC3  (7V Factory Default)					ENC4  (10V Factory Default)						
Fan output voltage of Low speed					Fan output voltage of Middle speed					Fan output voltage of High speed						
Dial code	0	1	2	3	4	5	6	7	8	9	A	B	C	D	E	F
Voltage(V)	1	1	2	3	4	5	6	7	8	9	10	10	10	10	10	10

Note: ENC2<ENC3<ENC4. If not satisfied, fault H9 is reported.

6.2 Capacity settings

The capacity DIP switches for the AHU control box should be set after the box is installed. The capacity can be set through ENC1 and SW4-2. After completing the settings, power off and then power on the unit to apply the settings.

Figure 6.2 Capacities of SW9 and ENC1

SW9 ON  1234	ENC1 	Capacity (hp)	Capacity (KW)	
	1	12.0 hp	33.5	MDX 33
	5	20.0 hp	56.0	MDX 56

6.3 Selection of Controllers

The Mistral MDX is controlled by a Pintherm Mistral. To apply the Pintherm Mistral, SW4-3 and SW4-4 must be set as follows:

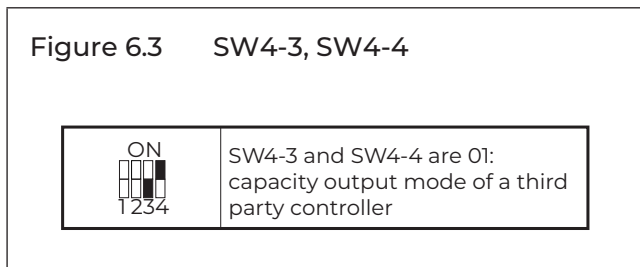

NOTE: After DIP switches on main board are set, remember to power off and then power on the main board to apply the settings. Otherwise, the settings will be invalid. When a third party controller is used, two control modes are available: capacity output control mode and set temperature control mode.

6.4.1 DIP switch settings overview Mistral MDX 33*

SW 1			
SW 1	SW 2	SW 3	SW 4
OFF	OFF	OFF	OFF

SW 2			
SW 1	SW 2	SW 3	SW 4
OFF	OFF	OFF	OFF

SW 3			
SW 1	SW 2	SW 3	SW 4
OFF	OFF	OFF	OFF

SW 4			
SW 1	SW 2	SW 3	SW 4
OFF	OFF	OFF	ON

SW 9			
SW 1	SW 2	SW 3	SW 4
OFF	OFF	OFF	ON

SW 10	
SW 1	SW 2
ON	OFF

ENC 1	1
ENC 2	2
ENC 3	7
ENC 4	A

6.4.2 DIP switch settings overview Mistral MDX 56*

SW 1			
SW 1	SW 2	SW 3	SW 4
OFF	OFF	OFF	OFF

SW 2			
SW 1	SW 2	SW 3	SW 4
OFF	OFF	OFF	OFF

SW 3			
SW 1	SW 2	SW 3	SW 4
OFF	OFF	OFF	OFF

SW 4			
SW 1	SW 2	SW 3	SW 4
OFF	OFF	OFF	ON

SW 9			
SW 1	SW 2	SW 3	SW 4
OFF	OFF	OFF	ON

SW 10	
SW 1	SW 2
ON	ON

ENC 1	5
ENC 2	2
ENC 3	7
ENC 4	A

* DIP-switch definition:

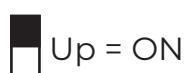
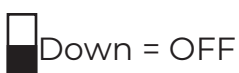

7 Electrical Wiring

7.1 General

CAUTION!

- » All installation and wiring must be carried out by competent and suitably qualified, certified and accredited professionals and in accordance with all applicable legislation.
- » Electrical systems should be grounded in accordance with all applicable legislation.
- » Overcurrent circuit breakers and residual-current circuit breakers (ground fault circuit interrupters) should be used in accordance with all applicable legislation.
- » Wiring patterns shown in this data book are general connection guides only and are not intended for, or to include all details for, any specific installation.
- » The refrigerant piping, power wiring and communication wiring are typically run in parallel. However, the communication wiring should not be bound together with the refrigerant piping or power wiring. To prevent signal interference, the power wiring and communication wiring should not be run in the same conduit. If the power supply is less than 10A, a separation of at least 300mm between power wiring and communication wiring conduits should be maintained; if the power supply is in the range 10A to 50A then a separation of at least 500mm should be maintained.

7.2 Power Supply Wiring

Power supply wiring design and installation should adhere to the following requirements:

- » Separate power supplies should be provided for the indoor unit and outdoor unit.
- » Installation must comply with the relevant local and/or national regulations.

7.3 Communication Wiring

Communication wiring design and installation should adhere to the following requirements:

- » 0.8mm² three-core shielded data cable should be used for communication wiring. Using other types of cable can lead to interference and malfunction.
- » Indoor communication wiring:
 - The P and Q communication wires should NOT be grounded.
 - The shielding nets of the communication wires should be connected together and grounded. Grounding can be achieved by connecting to the metal casing adjacent to the P Q E terminals of the outdoor unit electrical control box.
- » The on/off contact (connectors 10 and 11) can be used for:
 - Smart grid
 - Fire alarm
 - External on/off

The communication wires should be connected to the outdoor unit terminals indicated in the following paragraph.

7.4 Wiring example

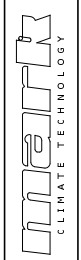
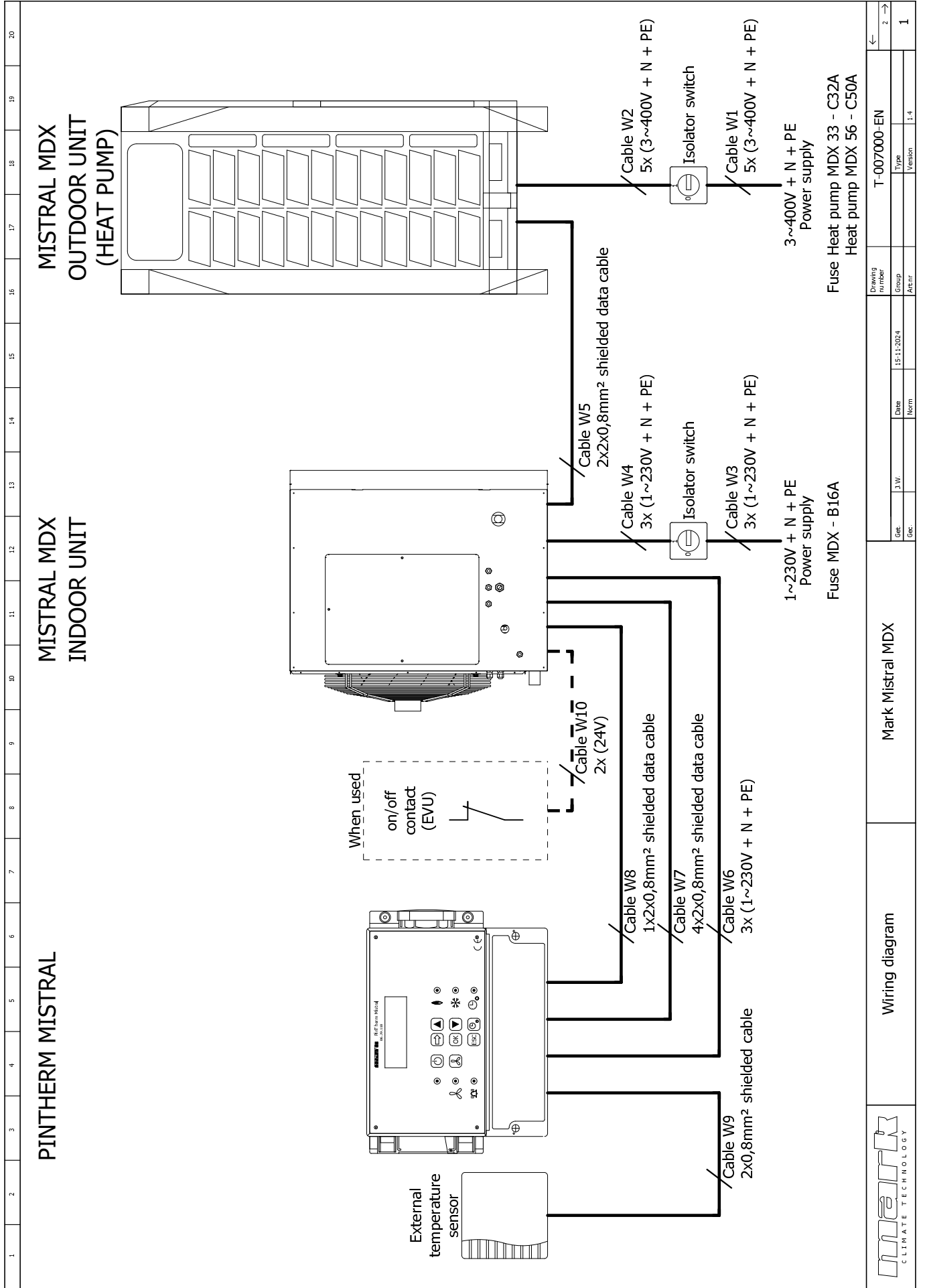

Wiring diagram

Mark Mistral MDX

Get.	J.W.	Date	Norm	Group	Act.ir	Version	1..4
		15-11-2014					1

Drawing number	Type	Version
T-007000-EN		1

Fuse Heat pump MDX 33 - C32A
Heat pump MDX 56 - C50A

3~400V + N + PE
Power supply

1~230V + N + PE
Power supply

Fuse MDX - B16A

MARK BV

BENEDEN VERLAAT 87-89
VEENDAM (NEDERLAND)
POSTBUS 13, 9640 AA VEENDAM
TELEFOON +31(0)598 656600
FAX +31 (0)598 624584
info@mark.nl
www.mark.nl

MARK EIRE BV

COOLEA, MACROOM
CO. CORK
P12 W660 (IRELAND)
PHONE +353 (0)26 45334
FAX +353 (0)26 45383
sales@markeire.com
www.markeire.com

MARK BELGIUM b.v.b.a.

KERNENERGIESTRAAT 47, UNIT G
2610 ANTWERPEN-WILRIJK
(BELGIË/BELGIQUE)
TELEFOON +32 (0)3 6669254
info@markbelgium.be
www.markbelgium.be

MARK DEUTSCHLAND GmbH

MAX-PLANCK-STRASSE 16
46446 EMMERICH AM RHEIN
(DEUTSCHLAND)
TELEFON +49 (0)2822 97728-0
TELEFAX +49 (0)2822 97728-10
info@mark.de
www.mark.de

MARK POLSKA Sp. z o.o

UL. JASNOGÓRSKA 27
42-202 CZĘSTOCHOWA (POLSKA)
PHONE +48 34 3683443
FAX +48 34 3683553
info@markpolska.pl
www.markpolska.pl

MARK SRL ROMANIA

STR. BANEASA NO 8 (VIA STR. LIBERTATII)
540199 TÂRGU-MURES, JUD MURES
(ROMANIA)
TEL/FAX +40 (0)265-266.332
office@markromania.ro
www.markromania.ro

