

INFRA AQUA ECO

Hot water radiant panels



WHAT IS RADIANT HEATING?	5
Comfort	5
Why radiant heating?	6
Zone or localised heating	6
System benefits	6
Chart (temperature gradient)	6

MARK INFRA AQUA ECO RADIANT PANEL	8
Benefits of Mark Infra Aqua Eco radiant panels	11
Application areas	11

APPLICATION IN A SPORTS HALL	12
Benefits in a sports hall	12
Ball removal plates	12
Direct mounting	12

TECHNICAL FEATURES	13
Dimensions	13
Heat output	14
Relationship between the minimum mass flow and return temperature	15
Cooling load	15
The calculation of pressure losses of the Mark radiant panels	16

Calculation of pressure losses in registers, collectors and connections	16
Type of collectors	18
Overview of hydronic connection and covers	18
Plates and panels	19



PROJECT PLANNING, ASSEMBLY AND SUSPENSION	20
Tight assembly against the ceiling	20
Press fittings	20
Mounting methods	21

CONTROL	22
----------------	----

QUOTATIONS	24
-------------------	----

LOGISTICS	25
Packing	25
Delivery and unloading	25
Finishing	25

ACCESSORIES & PARTS	25
--------------------------------	----

SPECIFICATIONS	26
-----------------------	----



What is radiant heating?

Radiant heating is based on the principle of the heat transfer of a warm body to a body with a lower temperature by means of electromagnetic wave energy. Provided this electromagnetic wave is not obstructed by air, it radiates walls, floor and other bodies in a specific room. These items absorb the radiated energy and then pass the heat on to the passing air. This produces a convective flow of slowly rising warm air and colder air that falls, which blend with each other (induction). The heating of the air in a space is mainly done by this convective airstream from the heated walls and floors. Heating a room by means of radiant panels always causes the floor temperature to be a few degrees higher than the room air temperature, which is experienced as very comfortable. Even directly under the radiation panel, the vertical temperature gradient is very low. As the roof is often the largest surface directly in contact with the outside air, with air heating more energy will be lost by heating this cold surface (see graphic "Temperature per meter height" on page 8).

Although this can be overcome by a high air circulation in the space, it requires extra energy. Consequently, drafts and dust occur and the floor and walls remain cold!

COMFORT

When our body gives more heat to its environment than it produces, we experience this as uncomfortable. The ideal method to heat cold surfaces is by means of radiant panels mounted on the ceiling which transfer their heat mainly through radiation.

People who are radiated in a room experience less heat loss and therefore more comfort. As a result, the room air temperature may be set a few degrees lower. This way, in addition to more comfort, energy can be saved.

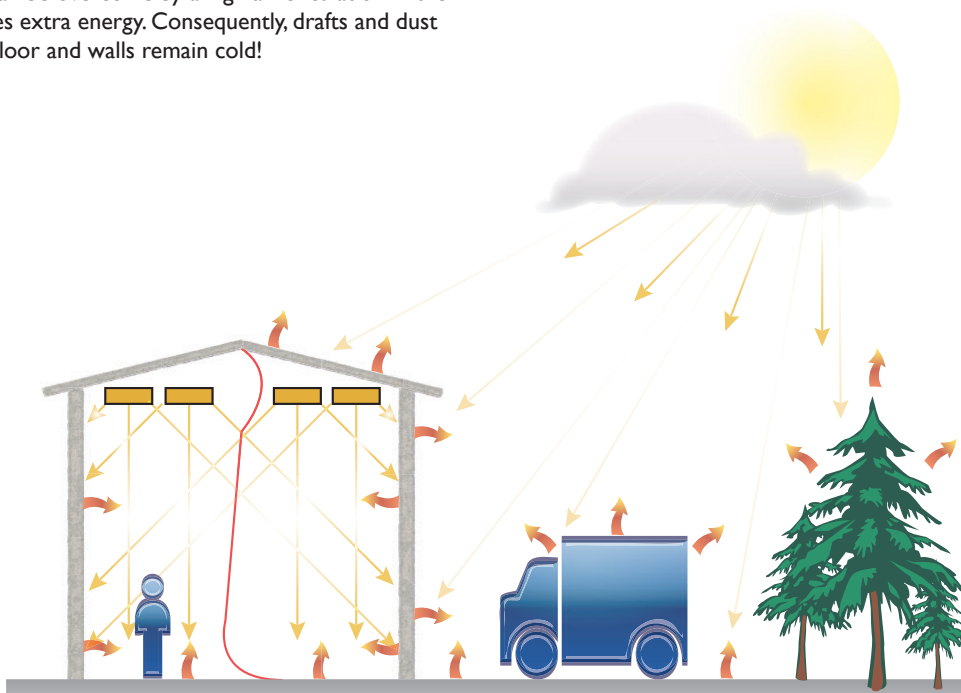

WHY RADIANT HEATING?

Radiant heating has been used for decades in areas ranging from 2.5 to 25 meters suspension height. Radiant heating is installed at places where it costs nothing, namely on the ceiling. Radiant heating is relatively quickly assembled, needs no maintenance, produces no noise and has a very long life.

ZONE OR LOCALISED HEATING

Radiant heating is also ideal for zone or local heating. Only the area to be heated is radiated. As a result, the energy costs are minimal.

SYSTEM BENEFITS

- Fast controllability through little water content.
- Uniform temperature distribution all over the horizontal area.
- Very low vertical temperature gradient.
- Zone or local heating is possible.
- Stationary air layer, no dust or drafts.
- Room temperature is 3°C lower than heating by radiators or air heating.
- 25-30% energy savings compared to conventional air heating.
- 15% less full load hours.
- Very long life.
- Completely maintenance free.
- Great comfort by direct radiation.
- Heated floor.
- Space saving.
- Silent.
- Can be applied everywhere due to unobtrusive design.

CHART (the difference in the vertical temperature gradient for radiation heating and air-heating)

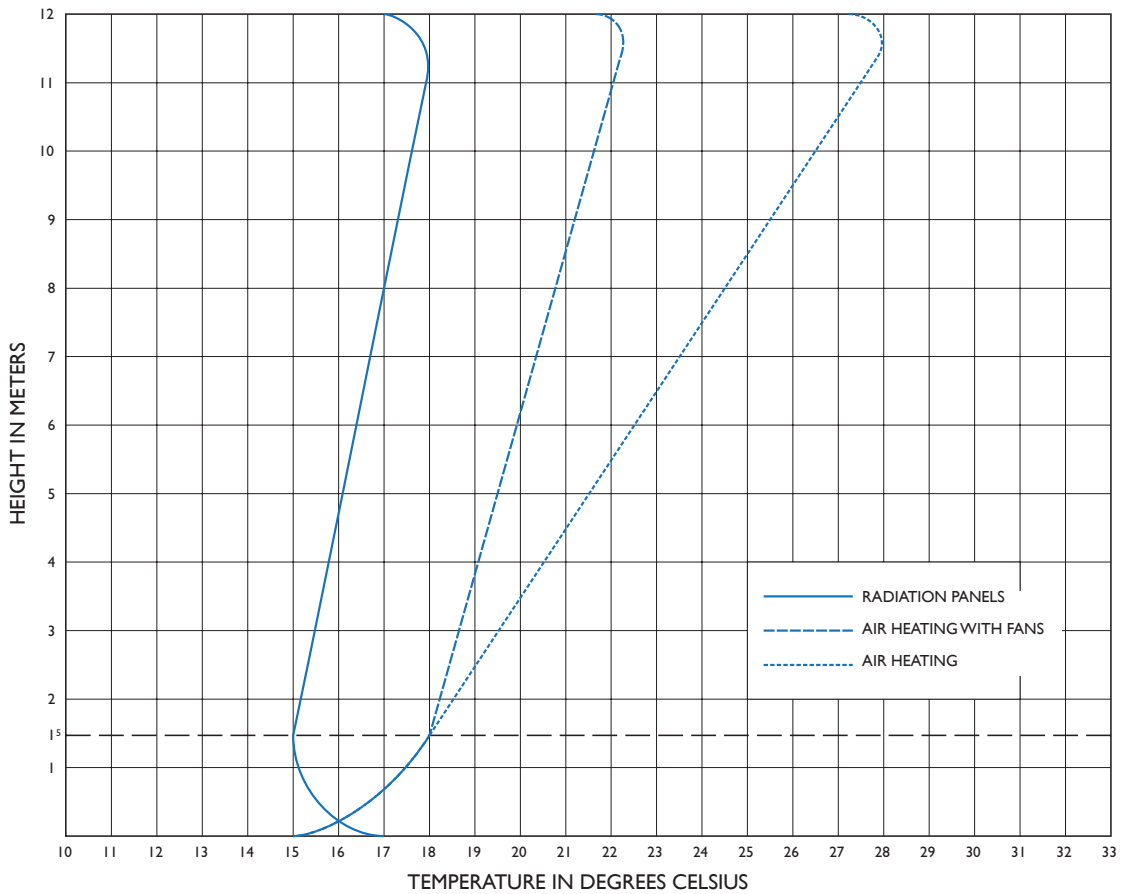



Mark Infra Aqua Eco radiant panel

The INFRA AQUA ECO radiant panel consists of a multiple of four pipes which are mounted on a profiled steel plate. Because the tubes are actually mounted in the profile of the steel sheet, there is a large contact surface. This is beneficial for the heat capacity. The radiation panel has to be insulated on the top side with the insulating material supplied separately (by the installer). This minimizes heat loss to the upper side of the room. The insulation strips must be set manually to length. The insulating material consists of mineral wool with a aluminium foil layer. The fire class of the insulation material is A2 (higher classes are available on request).

The INFRA AQUA ECO radiant panel has a very high heat output in watts per meter. This heat (see page 12) has been measured and certified by the HLK Stuttgart institute in accordance with EN 14037 1-3.

The panels are supplied in standard lengths of 4 or 6 meters. The panels are attached to each other with press fittings, longer lengths can be created. Take into account the water flow. In addition to the length options also the width is variable. The collectors will be mounted with press fittings as well. If necessary, the press fittings can be covered with a reflector cover plate which creates a neat finish.

Along with the standard black iron pipes, the panels can also be supplied with galvanized pipes. The collectors are already standard galvanized. The panel is thus suitable for cooling according to EN 14240.

The INFRA AQUA ECO is available in Revit (3D), have a look at www.markclimate.com for more information.

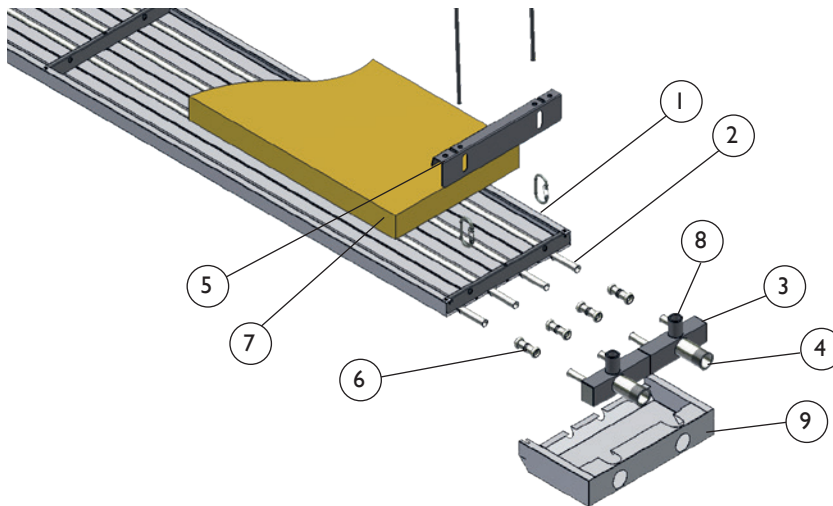

- 1 = Reflector
- 2 = Water tube
- 3 = Collector
- 4 = Water connection 1"
- 5 = Suspension set (profile and carabiners)
- 6 = Press-fittings (optional)
- 7 = Insulating material (supplied separately)
- 8 = De-aerater connection 1/2 " (air point not supplied by Mark)
- 9 = Cover plate (supplied separately)

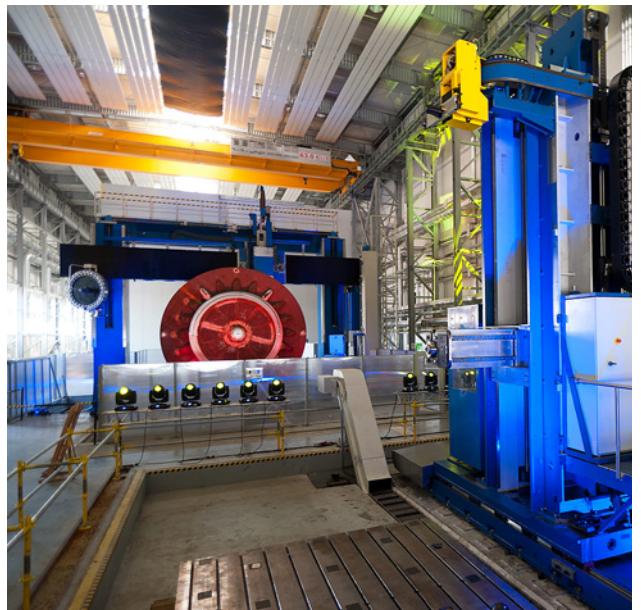
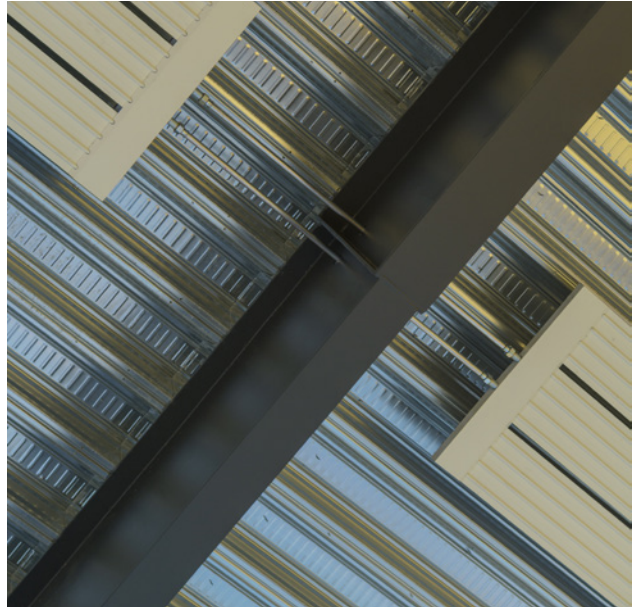



THE BENEFITS OF MARK INFRA AQUA ECO RADIANT PANELS

- High output of the panel, obtained by a large heating surface.
- Optimized mineral insulation covered with reinforced aluminum foil. Heat conductivity $0,045 \text{ W}/(\text{m} \cdot \text{k})$ at $60 \text{ }^\circ\text{C}$.
- Insulation material is pre-cut in the right width.
- Aesthetically beautiful panel.
- Standard colour RAL 9010 with scratchproof paint, optionally available in any RAL colour.
- Very low weight due to modular construction.
- Wide standard range of four types, lengths of 4 up to 80 meters.
- Galvanized collectors as standard.
- Galvanized design of the tubes for application in damp room and cooling (optional).
- Suspension bracket for easy installation.

APPLICATION AREAS

- Auto showrooms
- Furniture showrooms
- DIY-stores
- Schools
- Sports/Tennis halls
- Social (sheltered) workshops
- Bakeries
- Printing / Press rooms
- Paints factories
- Machine factories
- Fire stations
- Police stations
- Production halls
- Hospitals and nursing homes
- Logistic halls
- Areas with a danger of gas and/or explosion. Directive 94/9/EC (Atex 95).



Application in a sports hall

The most optimal way of heating a sports hall or gymnasium is by means of water based radiant panels. Spaces can be heated quickly and separately without the displacement of air and the associated noise. In addition to this, the panels on the ceiling do not form a danger to the users of the space.

Mark has an impressive reference for applications in sports halls and gymnasiums.

BENEFITS IN SPORTS HALL

- No air movement
- Zone control
- Silent
- Does not take up space
- Stand can be controlled separately

BALL REMOVAL PLATES

In order to prevent balls getting left stuck on the panels, ball removal plates can be mounted.

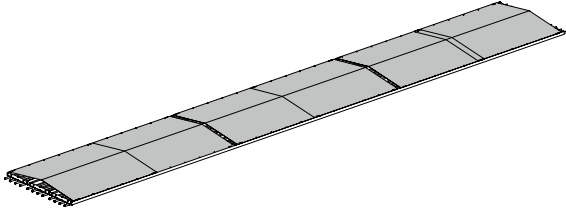

DIRECT MOUNTING

If the radiant panel is mounted tightly against the ceiling, no space is lost in a sports hall. Another advantage is that ball removal plates are unnecessary.



The brackets are equipped with a click system with an extra anchoring plug.

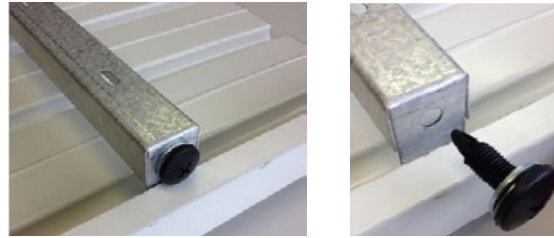

Technical Features

DIMENSIONS

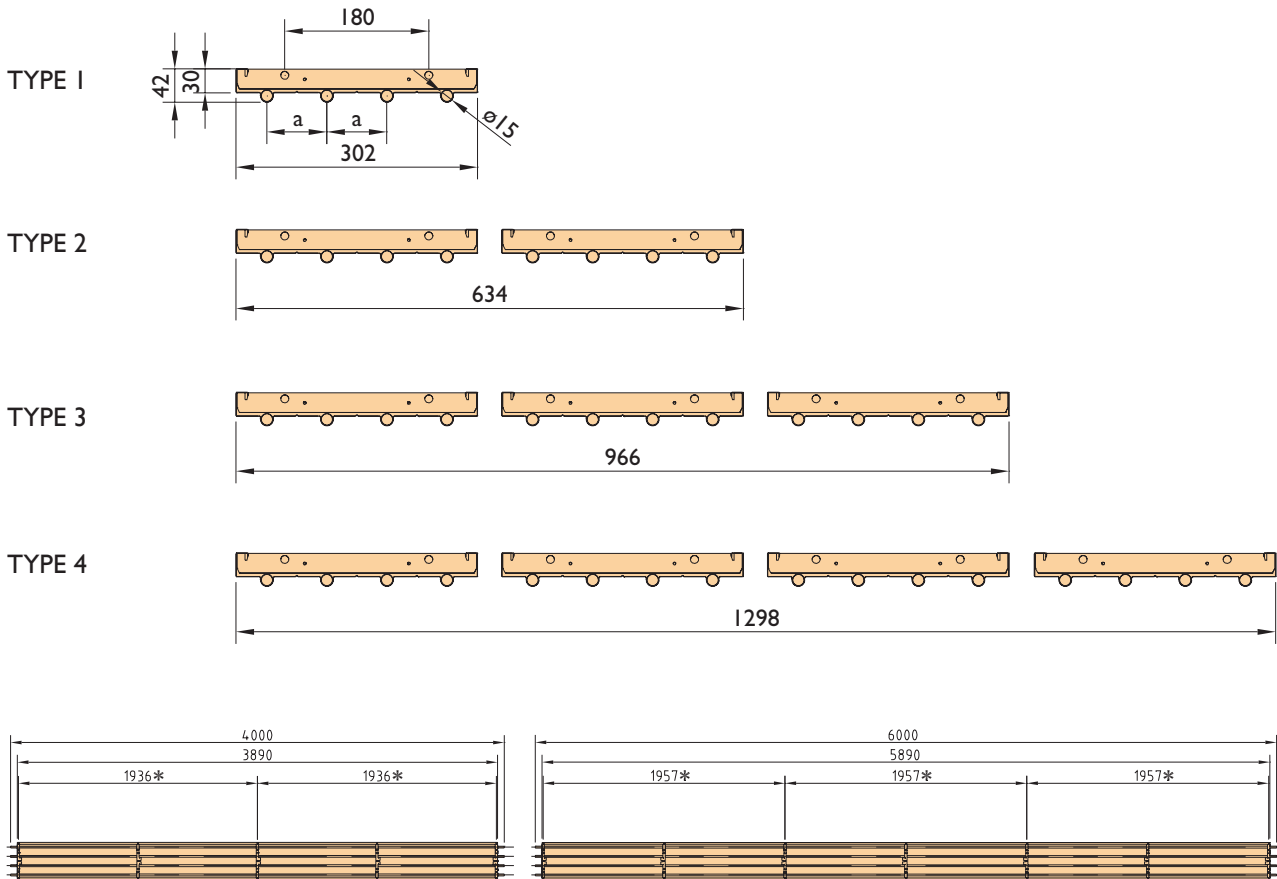

INFRA AQUA ECO		Type 1	Type 2	Type 3	Type 4
Tube Distance (a)	mm	75	75	75	75
Outside diameter tube	mm	15	15	15	15
Number of suspension points per axis	Pieces	2	2	2	2
Operating weight with water content and insulation (4 m)	kg	12,4	24,8	37,2	50
Operating weight with water content and insulation (6 m)	kg	18,5	37	55,5	74

max. working temperature: 120°C max operating pressure: 10 bar

* Heart to heart distance suspension points.

HEAT OUTPUT

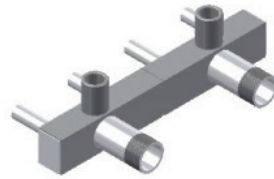

Heat output table for panels in watts / m in accordance with EN 14037 1-3

Heat output table per two collectors in watts / unit in accordance with EN 14037 1-3

Medium overtemp K	Type 1	Type 2	Type 3	Type 4	Medium overtemp K	Type 1	Type 2	Type 3	Type 4
115	476	952	1428	1904	115	165	330	494	659
110	451	903	1354	1806	110	156	312	468	624
105	427	855	1282	1709	105	147	295	442	590
100	403	807	1210	1613	100	139	278	417	556
95	380	759	1139	1518	95	131	261	392	522
90	356	712	1068	1424	90	122	244	367	489
85	333	666	998	1331	85	114	228	342	456
80	310	619	929	1239	80	106	212	318	423
75	287	574	861	1148	75	98	196	293	391
70	264	529	793	1058	70	90	180	270	360
69	260	520	780	1040	69	88	177	265	353
68	256	511	767	1022	68	87	174	260	347
67	251	502	753	1004	67	85	170	256	341
66	247	493	740	987	66	84	167	251	335
65	242	485	727	969	65	82	164	246	329
64	238	476	714	951	64	81	161	242	322
63	233	467	700	934	63	79	158	237	316
62	229	458	687	916	62	78	155	233	310
61	225	449	674	899	61	76	152	228	304
60	220	441	661	881	60	74	149	223	298
59	216	432	648	864	59	73	146	219	292
58	212	423	635	847	58	71	143	214	286
57	207	415	622	830	57	70	140	210	280
56	203	406	609	812	56	68	137	205	274
55	199	398	596	795	55	67	134	201	268
54	195	389	584	778	54	66	131	197	262
53	190	381	571	761	53	64	128	192	256
52	186	372	558	744	52	63	125	188	250
51	182	364	545	727	51	61	122	183	244
50	178	355	533	710	50	60	119	179	239
49	173	347	520	694	49	58	116	175	233
48	169	338	508	677	48	57	113	170	227
47	165	330	495	660	47	55	111	166	221
46	161	322	483	644	46	54	108	162	215
45	157	314	470	627	45	52	105	157	210
44	153	305	458	611	44	51	102	153	204
43	149	297	446	594	43	50	99	149	198
42	144	289	433	578	42	48	96	145	193
41	140	281	421	562	41	47	94	140	187
40	136	273	409	546	40	45	91	136	182
39	132	265	397	529	39	44	88	132	176
38	128	257	385	513	38	43	85	128	171
37	124	249	373	497	37	41	83	124	165
36	120	241	361	482	36	40	80	120	160
35	116	233	349	466	35	39	77	116	154
30	97	194	291	388	30	32	64	96	128
25	78	156	235	313	25	26	51	77	102
20	60	120	180	240	20	19	39	58	78
15	43	85	128	171	15	14	27	41	55

K = Average water temperature - room temperature. Values at a mass flow of 0.04 liters per second / pipe.

RELATIONSHIP BETWEEN THE MINIMUM MASS FLOW AND RETURN TEMPERATURE

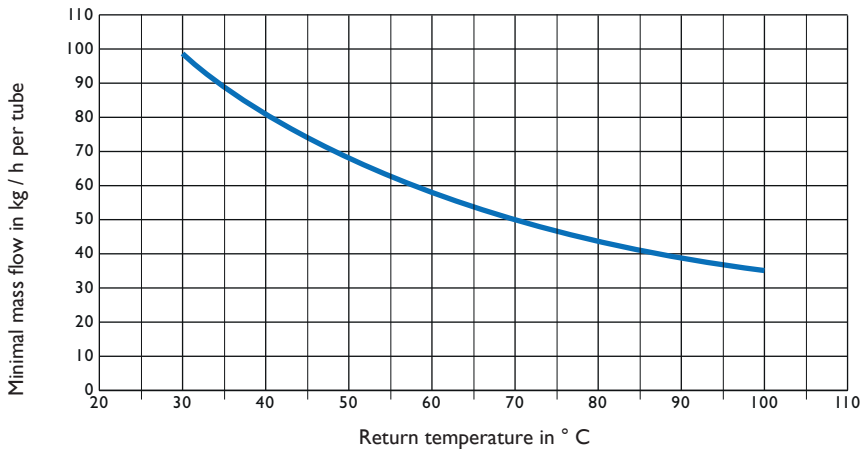

COOLING LOAD

with glass wool insulation				
Delta T (ΔT) [K]	1 panel [W/m]	2 panels [W/m]	3 panels [W/m]	4 panels [W/m]
1	3	6	9	13
2	6	13	19	26
3	10	19	29	39
4	13	26	39	52
5	17	33	50	66
6	21	42	63	84
7	25	50	75	100
8	28	56	84	112
9	32	64	96	128
10	36	72	108	144
11	39	78	117	156
12	43	86	129	172
13	46	92	138	184
14	48	96	144	191
15	51	103	154	206

without insulation				
Delta T (ΔT) [K]	1 panel [W/m]	2 panels [W/m]	3 panels [W/m]	4 panels [W/m]
1	4	8	11	15
2	8	15	23	31
3	12	23	35	47
4	16	31	47	63
5	20	39	59	79
6	24	47	71	95
7	28	56	83	111
8	32	64	96	127
9	36	72	108	144
10	40	80	120	160
11	44	88	132	177
12	48	97	145	193
13	52	105	157	210
14	57	113	170	226
15	61	121	182	243

Delta T (ΔT) = Room temperature - Average water temperature

Example

Desired room temperature: = 24 °C

Water temperature: 6/12 = 9 °C

24 - 9 = 15 °C

THE CALCULATION OF PRESSURE LOSSES OF THE MARK RADIANT PANELS

The most optimally selected panel types have the lowest possible resistance and yet sufficient mass flow.

The type of panel is defined by:

- The mass flow of the medium per panel.
- The method of connection of the hydraulic system.
- The connection diameter.

The mass flow per panel is calculated using the output and the difference between the flow and return temperature:

$$M = \frac{P}{C_p \times \Delta t} \quad \text{kg/s or} \quad \frac{P \times 0,86}{\Delta t} \text{ kg/h}$$

P = total release of the panel W

Δt = temperature difference between supply and return temperatures

C_p = specific heat of water $\pm 4200 \text{ J / (kg.K)}$

$$K = \frac{T_a + T_r}{2} - T_u$$

T_a = flow temperature of the water

T_r = return temperature of the water

T_u = room temperature

CALCULATION OF PRESSURE LOSSES IN REGISTERS, COLLECTORS AND CONNECTIONS

R = resistance of water per panel length in Pa / m

Z = water resistance in Pa for both collectors

m = mass flow per panel (kg / h)

$$R = \left(\frac{m}{\frac{\text{tubes}}{173}} \right)^2 \times 196 \quad Z = \left(\frac{m}{1000} \right)^2 \times 2000$$

Example:

INFRA AQUA ECO type 2 collector A (30 meters)

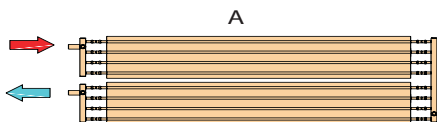

Water temperature 80/60 (15 ° C)

$$m = \frac{P}{C_p \times \Delta T} = \frac{((30 \times 398 \text{ W}) + 67\text{W})}{4200 \times \left(\frac{80}{60} \right)} = \frac{12007}{84000} = 0,143 \text{ kg/s} \times 3600 = 515 \text{ kg/h}$$

CALCULATION OF RESISTANCE

LB = track length (30m x 2)

R = tube resistance per meter (Pa/m)

Z = collective resistance (Pa)

$$\Delta P = LB \times R + Z$$

Example:

$$R = \left(\frac{515}{\frac{4}{173}} \right)^2 \times 196 = 109 \text{ Pa/m} \quad Z = \left(\frac{515}{1000} \right)^2 \times 2000 = 530 \text{ Pa (per panel)}$$

$$\Delta P = (2 \times 30\text{m} \times 109) + 530 = 7.070 \text{ Pa} = 7,07 \text{ k Pa}$$



TYPE OF COLLECTORS

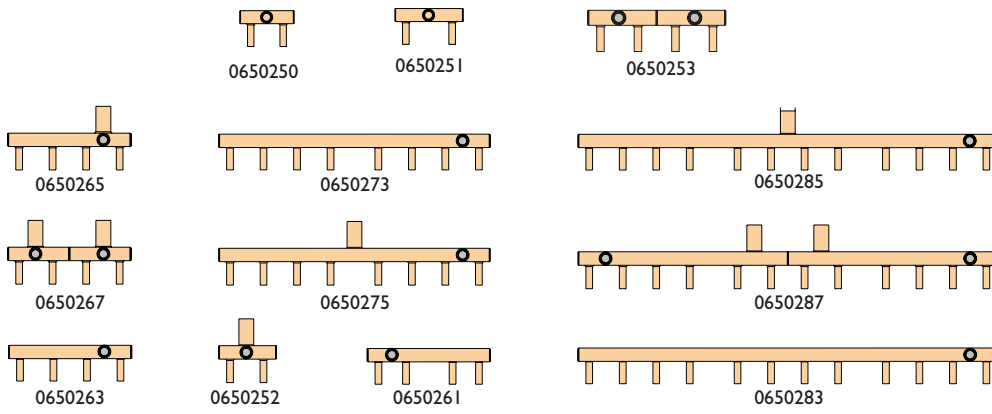

OVERVIEW HYDRONIC CONNECTION AND COVERS

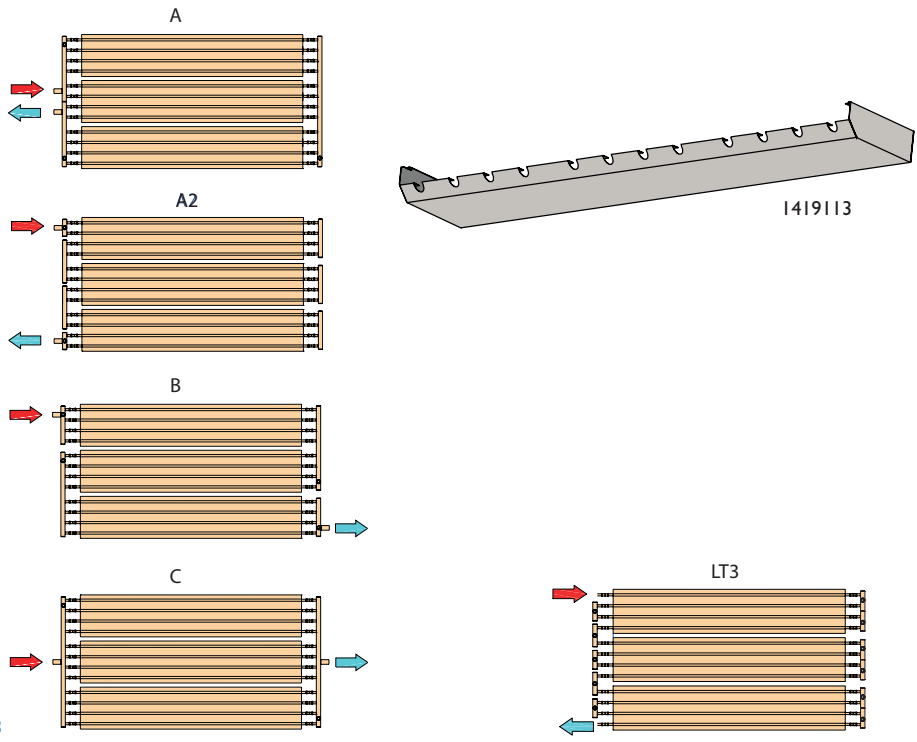
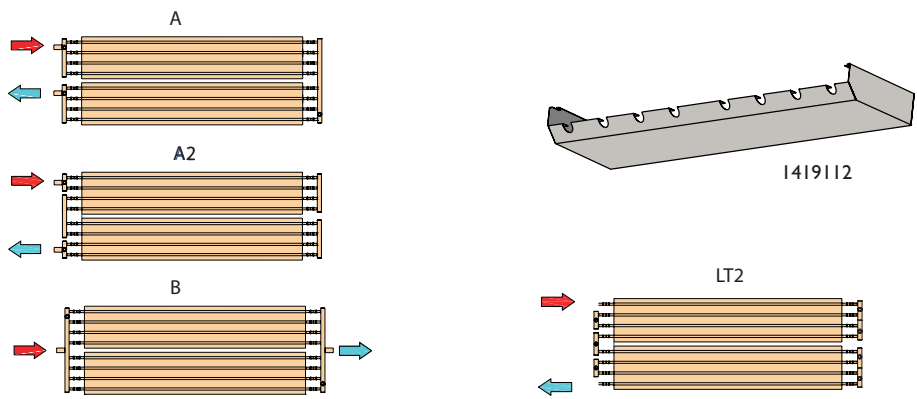
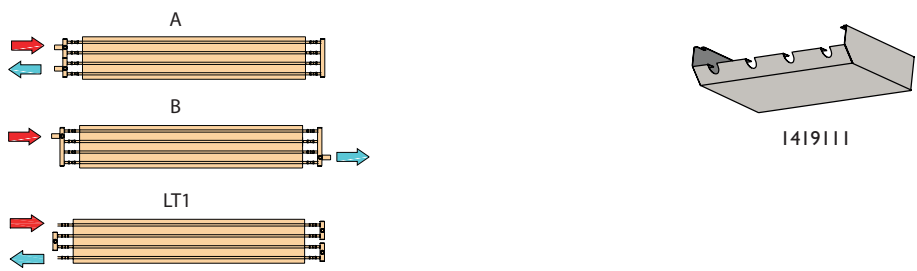

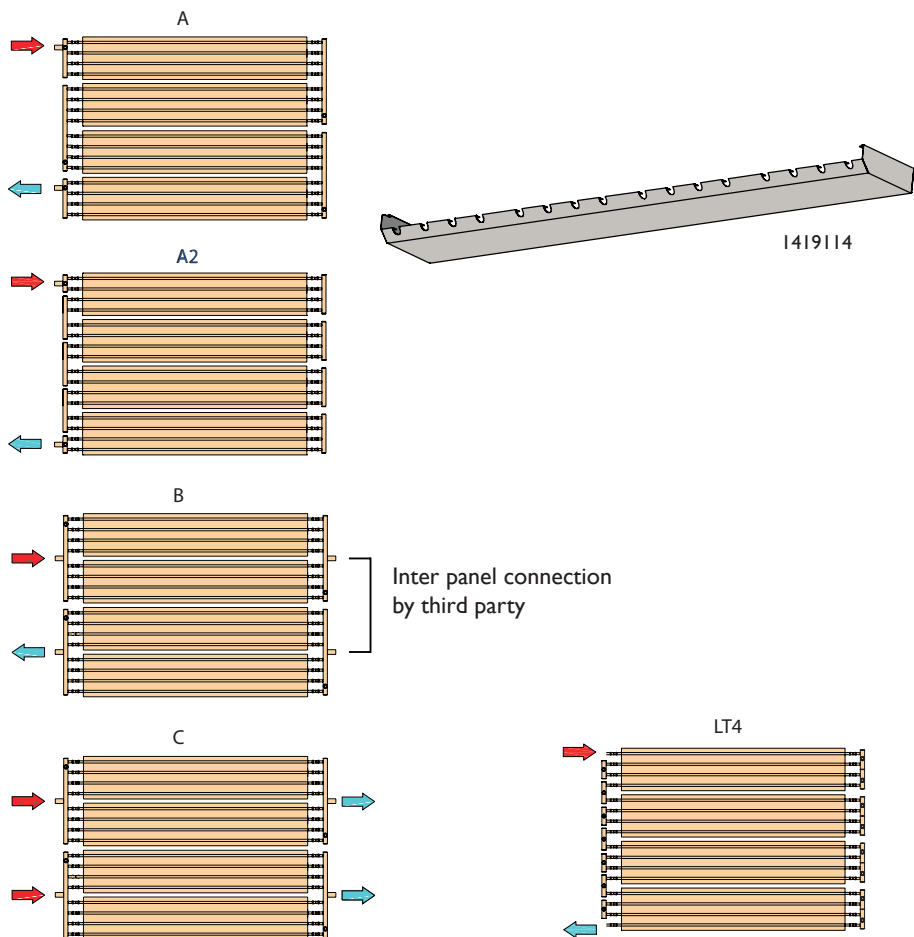

PLATES AND PANELS

The Infra Aqua Eco radiant panels are fitted with cover plates between the panels and covers on the collectors. Depending on the location of the water connection the corresponding press-through holes can be opened. This should be done on site.

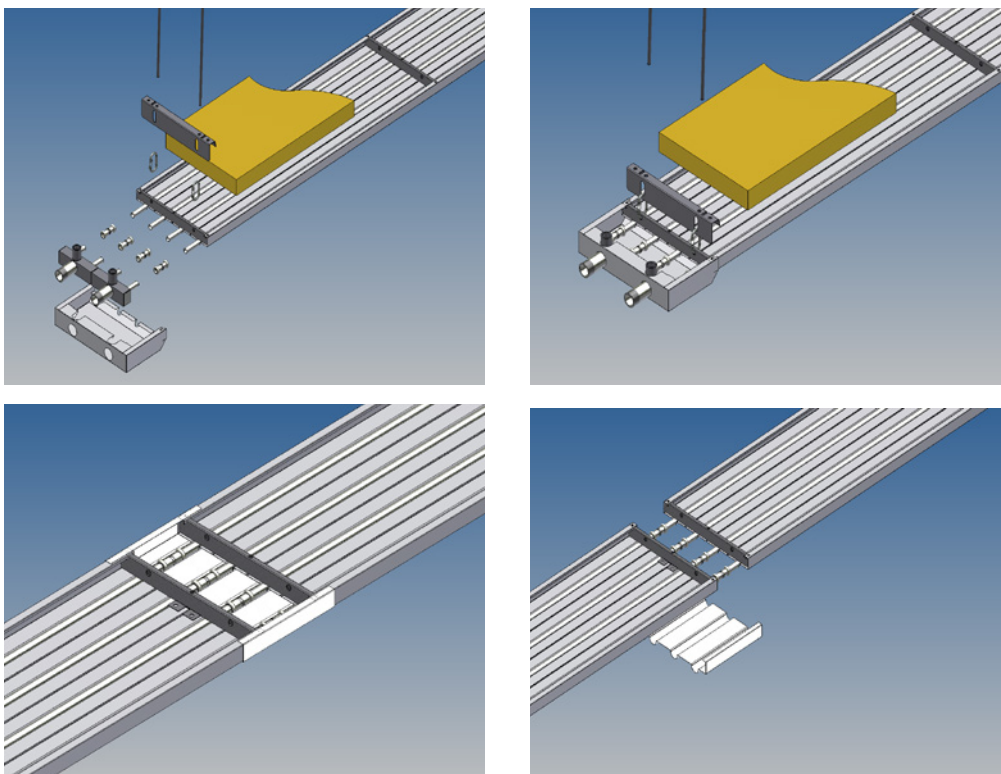

Project planning, assembly and suspension

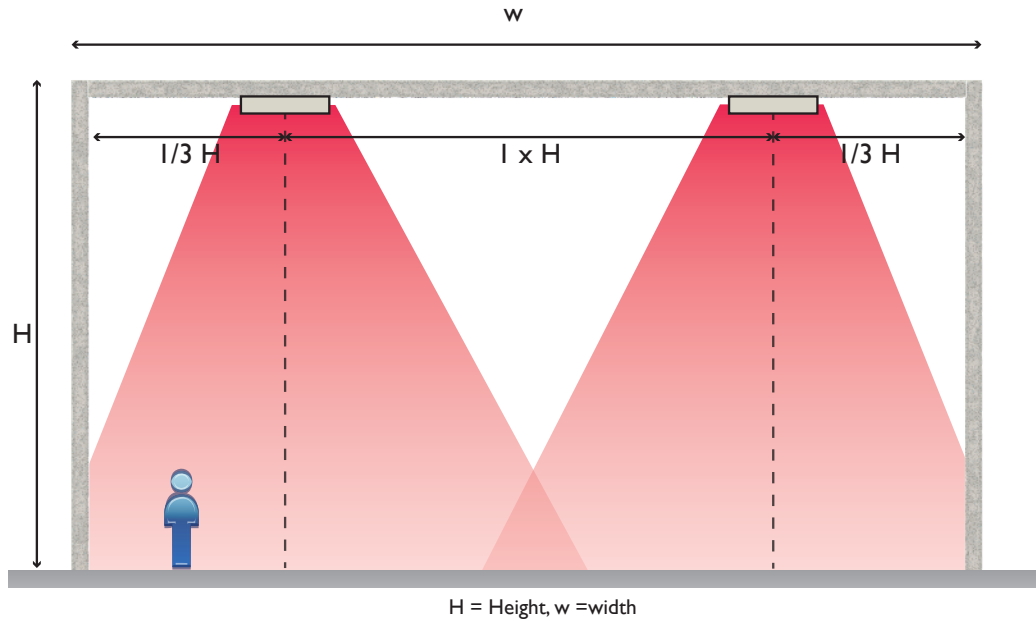

TIGHT ASSEMBLY AGAINST THE CEILING

When the panel is mounted tightly against the ceiling, an attractive effect is created. When used in a sports hall no ball removal plates will be needed.

Through a special mounting bracket, the panels can be mounted tight against the ceiling. The bracket is adapted to mount one single panel (type I).



PRESS FITTINGS

Mark Climate Technology delivers approved press fittings as an option. Applying other fittings can lead to leaks for which Mark Climate Technology cannot be held liable.



B

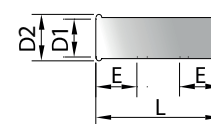

	D1	L	D2	E
B	15	80	23	25

MOUNTING METHODS

Method A
Suspension by means of threaded rods

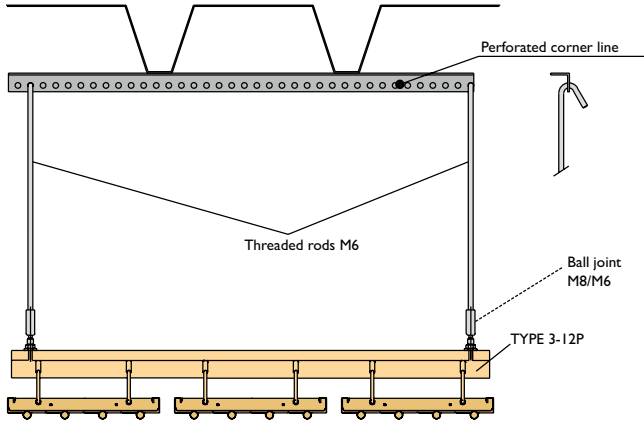

Method B
Suspension by means of steel wire

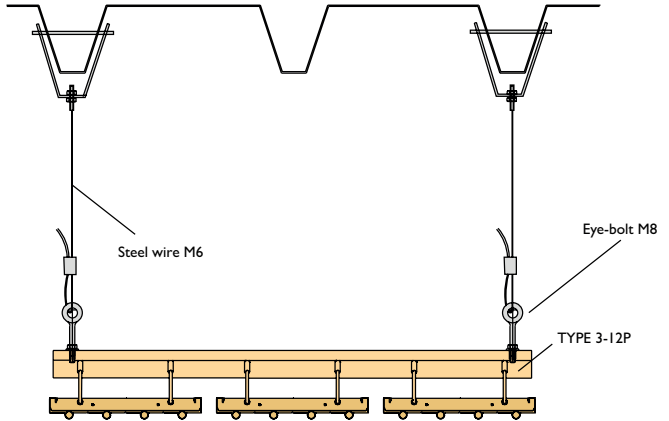

Method C
Suspension by means of hangers

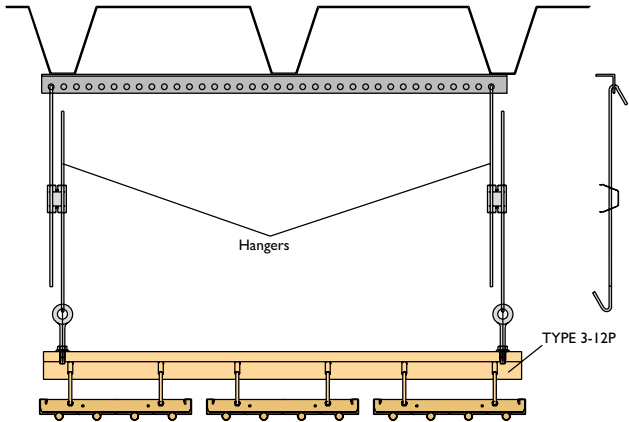

Method D
Suspension by means of hangers

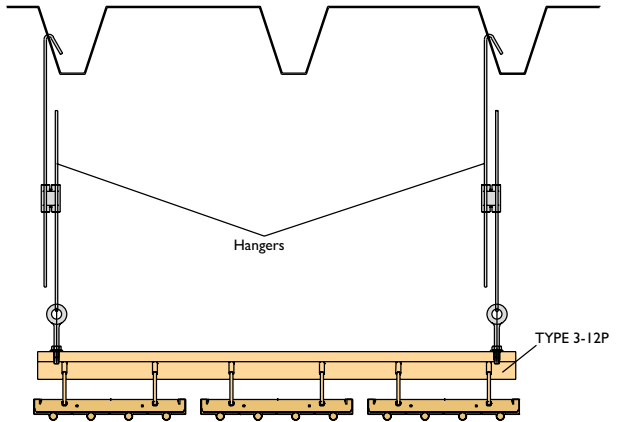

Method E
Suspension by means of chains and carabiners

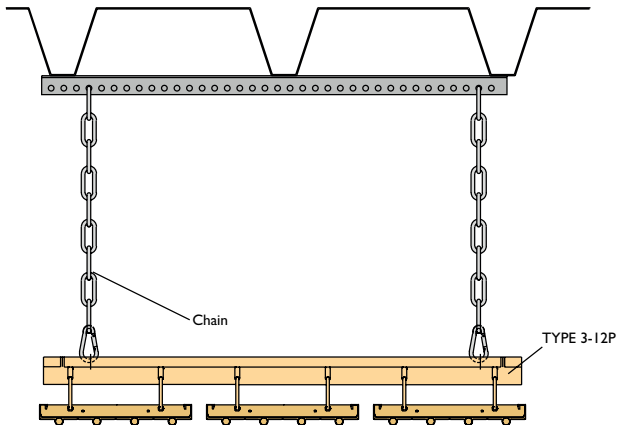

Method F
Suspension by means of chains and tensioners

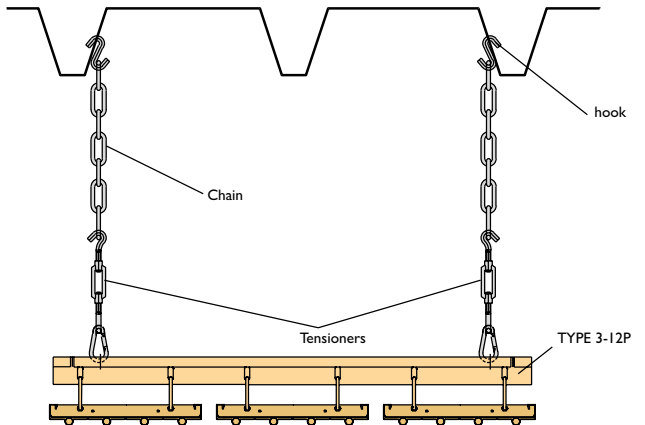

Method G
Suspension by means of chains and carabiners

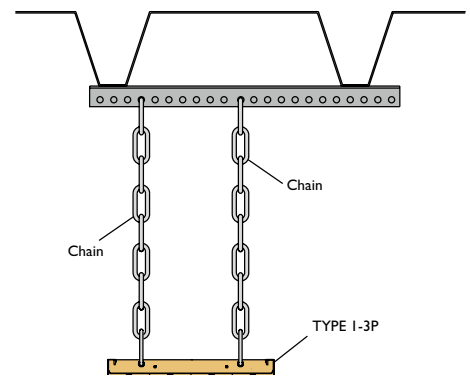

Method H
Suspension tightly against the ceiling



Control

HYDRONIC

Little water content in the system and a relatively high flow rate of the heating medium results in a very good controllability of the installation. To maintain a constant design temperature, the control should be arranged through the flow temperature of the heating medium based on a mixed control, so that a turbulent flow in the tubes is maintained.

WEATHER DEPENDENT FLOW TEMPERATURE CONTROL

With room temperature compensation

The set value X_s of the outdoor controller is altered until the desired temperature t_i is reached.

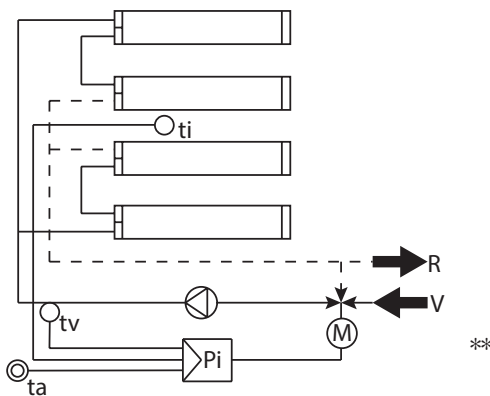

ROOM TEMPERATURE

The room temperature is preferably controlled by means of a black bulb sensor (see accessories).

ZONE CONTROL

In order to obtain different indoor temperatures t_i

For example, a production area of 18°C and a warehouse of 16°C. The outdoor temperature control as pre-control enables to work with a higher supply temperature than is strictly necessary for the individual zones.

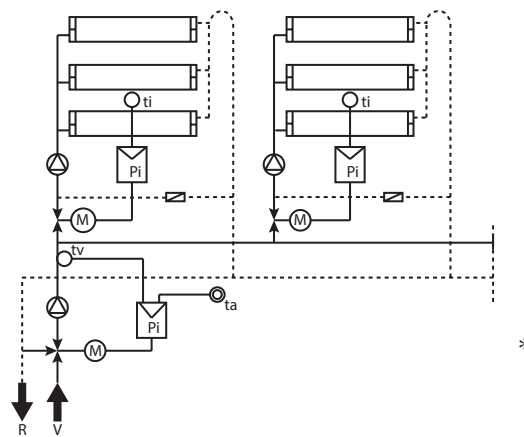

ZONE INDOOR TEMPERATURE CONTROL

By disconnecting and ringing of the radiant panels

Weather dependent flow temperature control with PI controller, that supplemented by a room thermostat controlled solenoid valve, which switches a portion of the hydronic heated surface in case the set value X_s of the room thermostat is exceeded. With a pump multiple zones can be fed hydronically. Each zone is hydronically divided in at least two groups. This is a very convenient control system for installation with extreme heat load and for the time-controlled temperature reductions (e.g. night and weekend reductions).

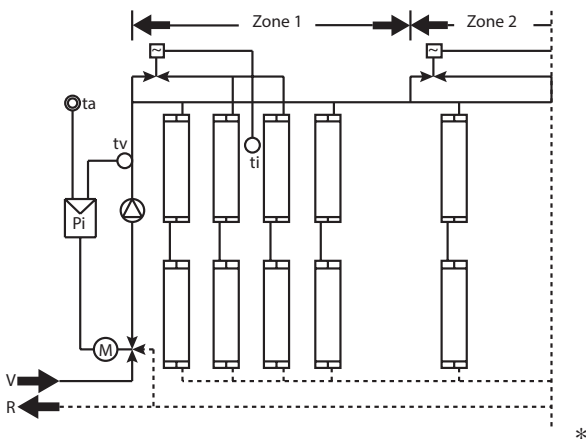

WEATHER DEPENDENT FLOW TEMPERATURE CONTROL 2

Handling (no control) of the inside temperature t_i by the flow temperature t_v .

Simplest solution, without feedback from the indoor temperature t_i .

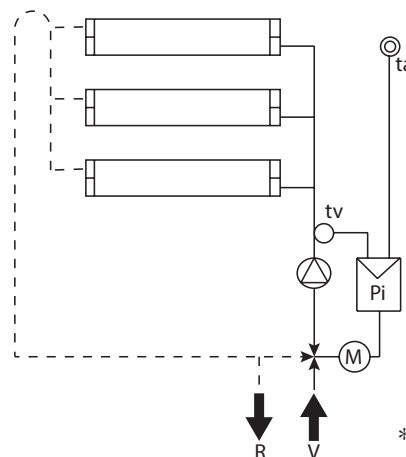

* Pipe network according to Tichelman.

** Pipe network with series arrangement to provide the outer panels with a higher heat output.

ta = outside temperature | ti = inside temperature | tv = supply temperature | Pi = regulator | R = return line | V = supply line
M = motor operated valve |  = cartridge



Quotations

The Infra Aqua Eco radiant panel quotations are calculated by means of selection software. In an overview on one A4 you will receive all relevant information such as heating capacity, pressure loss, collector types, volume flow, and of course the price.

Company name: InfraEco English Date: 01.09.2015

Project number: 2221224 Number of rows: 5

Control: SW-32 Act Pipes: 35

Position number: 1 Rows: 0

Component supplier: Mr. Mark Pipes: 100 | 100

System configuration: Tubes: Manual Computer

Water temperature: 80 °C
 Return: 60 °C
 Ambient temperature: 17 °C

No.	Ref.	Q	W	Length	Connection variation	Amount	Subsidiary per meter	Subsidiary total	Subsidiary panel length	Volume circuit (total)	Volume circuit per pipe	Volume circuit per panel	Pressure loss total	Price
							W/m	W/m	W/m	kg / s	kg / s	kg / s	SPa	€
1	RP1	2	30	2A	4	397.63	4820.52	10462.76	50.00	52.67	50.30	1.05	1.046.001	
2	RP2	3	20	3A	6	796.44	12718.63	10263.77	50.00	56.30	52.59	0.50	5.202.001	
3	RP3	4	40	4A	3	796.25	96234.27	12075.69	50.00	104.24	107.06	0.04	9.054.001	
4	RP4													
5	RP5													
							Total selected subsidiary (W)	227.26					Total	15.304.001

Copyright © 2015 MARK ClimateTech GmbH. All rights reserved. No part of this publication may be reproduced, stored in a retrieval system, or transmitted, in any form or by any means, electronic, mechanical, photocopying, recording or otherwise without prior written permission of the publisher. 04Jun.2015



Logistics



Transport unit
(Maximum stack of 20 panels per pallet)

PACKING

Each Mark radiant panel is wrapped in protective foil and stacked up to a maximum of 20 panels. Panels with mineral wool insulation are stacked alternately and fixated with wood. Everything is transported on a pallet that is equipped with lifting points.

DELIVERY AND UNLOADING

Mark radiant panels are manufactured with extreme care and after final inspection (each panel is manually cleaned and checked), much attention is paid to the packaging and transport.



FINISHING

Mark delivers the panels standardly in colour RAL 9010. As an option, any RAL colour is available at an additional charge.

Accessories & parts

Possible accessories to be supplied are:

- Volume flow controllers
- High-pressure cartridge
- Press fittings
- Ball removal plate
- Black bulb sensor



Specifications

- Mark radiant panels consisting of water-pipes. Pipe distance standard 75 mm.
- Standard black tube. Galvanized pipe is available on request. Suspension profile include two mounting holes for immediate suspension or carabiners.
- Supplied with loose delivered collectors, consisting of profiled tube 40 x 30 x 2.5 mm at the ends provided with welded end plates. Collectors are galvanized. Collectors are equipped with the necessary connector fittings: 1/2".
- Steel profiled panels, visible side foreseen with a polyester coating, RAL 9010 matt. Temperature up to 120 °C. Sheet thickness 0.5 mm. Pipes are held in place by means of suspension profiles.
- Optimized mineral insulation covered with reinforced aluminum foil. Heat conductivity 0,045 W/(m • k) at 60 °C.
- Fire class A2-S1.
- Covered with reinforced double-layer aluminum.
- The panels are supplied with mounting kits consisting of a mounting bracket and two carabiners per panel in order to keep an equal distance between the panels.
- Between the panels there are metal covers, width 150 mm x 306 mm, color RAL 9010, equipped with slotted holes 3 x 9 mm for the purpose of fixation.
- Metal end cap, width 100 mm, color RAL 9010. Applied after mounting to finish the collector.
- Standard panel lengths of 4 and 6 meters. Lengths from 4 to 50 m² can be supplied on request.
- Packing: panels are wrapped in foil and packed on a robust pallet equipped with lifting points.
- Because of transport, the panels are supplied in maximum lengths of 6 meters and will be assembled into the desired track length by the installer on the project site.
- Brackets between the suspension profile and the roof are optionally available. See page 18.
- Working pressure up to 10 bar.





mark
CLIMATE TECHNOLOGY
FOR A HEALTHY CLIMATE
WWW.MARKCLIMATE.COM

MARK Climate Technology
Beneden Verlaat 87-89
9645 BM Veendam
The Netherlands
T: +31(0)598 656623
E: info@markclimate.com
I: www.markclimate.com

MARK EIRE BV
Coolea, Macroom
Co. Cork
P12 W660 (Ireland)
T: +353 (0) 26 45334
E: sales@markeire.com
I: www.markeire.com

